



**GOVERNMENT OF MALAWI**

**MINISTRY OF AGRICULTURE, IRRIGATION AND  
WATER DEVELOPMENT**

**SHIRE VALLEY IRRIGATION PROJECT**

**Environmental and Social Impact  
Assessment (ESIA) and Pest  
Management Plan (PMP) for the  
Shire Valley Irrigation Project (SVIP)**

**Pest Management Plan (PMP) of the SVIP**

**Final Report**

**June, 2017**

**BRLi, Nîmes France**





**BRL ingénierie**

**1105 Av Pierre Mendès-France BP 94001  
30001 NIMES CEDEX 5**

<b>Date</b>	<b>April, 2017</b>
<b>Contacts</b>	<b>Eric Deneut, Gilles Pahin</b>

<b>Document title</b>	<b>Pest Management Plan (PMP) of the Shire Valley Irrigation Project (SVIP) Final report</b>
<b>Reference</b>	<b>800816</b>
<b>Version</b>	<b>V.5</b>

<b>Date</b>	<b>Version</b>	<b>Comments</b>	<b>Written by</b>	<b>Validated by</b>
01/06/2016	V1	Draft version	Dominique Olivier: Integrated Pest Management Specialist	Gilles Gilles Pahin, Team Leader / ESIA/ESMP Expert
31/08/2016	V2	Final version		
26/04/2017	V3	Final version		
26/05/2017	V4	Final version based on comments from the WB RSA		
07/06/2017	V5			

# **PEST MANAGEMENT PLAN (PMP) OF THE SHIRE VALLEY IRRIGATION PROJECT (SVIP) FINAL REPORT**

## **Table of content**

<b>1. INTRODUCTION .....</b>	<b>1</b>
<b>2. BACKGROUND INFORMATION ON THE PROJECT .....</b>	<b>4</b>
<b>3. POLICY LEGAL AND INSTITUTIONAL FRAMEWORK OF INTEGRATED PEST MANAGEMENT PLAN .....</b>	<b>6</b>
3.1 Policies	7
3.1.1 The National Environmental Policy (2004)	7
3.1.2 World Bank Safeguard Policies – Pest Management Policy ( OP 4.09)	7
3.2 Legal framework	8
3.2.1 The Pesticide Act (2000)	8
3.2.2 Pesticides Regulations (2002)	8
3.2.3 The Environment Management Act (60:02)	8
3.2.4 The Water Resource Act (2013)	9
3.2.5 Plant Protection Act	9
3.3 Institutional framework	9
<b>4. CURRENT PESTICIDE USES, CHALLENGES AND IPM AWARENESS IN MALAWI .....</b>	<b>10</b>
<b>5. EXISTING AND ANTICIPATED PESTS AND DISEASES PROBLEMS ON IRRIGATION SCHEMES .....</b>	<b>11</b>
5.1 Current irrigated crops and future cropping pattern	11
5.2 Major pests and diseases of Sugarcane	14
5.2.1 Yellow sugarcane aphids	14
5.2.2 Termites	17
5.2.3 Rodents	17

5.2.4	Red spider mite	18
5.2.5	Other insects	18
5.2.6	Rust	18
5.2.7	Smut	19
5.2.8	Pokka Boeng	19
5.2.9	Weed control	19
5.2.10	Chemical ripening	20
5.3	Major pests and diseases of Cotton	20
5.3.1	Weeds	20
5.3.2	Insects	20
5.3.3	Disease	22
5.4	Major pests and diseases of Tropical fruits	23
5.4.1	Banana	23
5.4.2	Mangoes	24
5.5	Major pests and diseases of Maize / Sorghum	26
5.5.1	Weeds	26
5.5.2	Insects	26
5.6	Major pests and diseases of Rice	27
5.7	Major pests and diseases of Beans	28
5.8	Major pests and diseases of Horticultural crops	28
5.9	Synthesis of pesticides used in Shire valley	30
5.9.1	Toxicity for human health and environment of the pesticides used	30
5.9.2	Environmental and safety concerns with pesticides	33
<b>6.</b>	<b>INTEGRATED PEST CONTROL AND MANAGEMENT OPTIONS .....</b>	<b>34</b>
6.1	Importance of IPM	34
6.2	Risks	34
6.3	Potential impacts and challenges associated with SVIP implementation	35
6.4	Proposed management options	37
6.4.1	Pest Problems and Control Practices	37
6.4.2	Recommended list of pesticides	40
6.4.3	Safety Management Systems	41
6.4.4	Mitigations and activities to be implemented	43
<b>7.</b>	<b>MONITORING INTEGRATED PEST MANAGEMENT PLAN .....</b>	<b>48</b>
7.1	Monitoring & Evaluation	48
7.2	IPM implementation team	49
7.3	Capacity Building programme	50

7.4 Institutional Arrangements	51
7.5 Indicative Budget for PMP Implementation	52
<b>APPENDICES .....</b>	<b>54</b>
Appendices 1. Bibliography	55
Appendices 2. Persons contacted	57
Appendices 3. FAO Guideline on Management Options for Empty Pesticide Containers	59

## ABBREVIATIONS AND ACRONYMS

ADD	Agricultural Development Division
AESA	Agro-ecosystem Analyses
AfDB	African Development Bank
AgDPS	Agricultural Development Planning Strategy
ASWAp	Agricultural Sector Wide Approach
ASWAp-SP	ASWAp – Support Project
BT	Bacillus Thuringiensis
DARTS	Department of Agricultural Research & Technical Services
EPA	Environmental Protection Agency
ESCOM	Electricity Supply Corporation of Malawi Limited
ESIA	Environmental and Social Impact Assessment
ESMP	Environmental and Social Management Plan
EU	European Union
FAO	Food and Agriculture Organization
FBOs	Farmer Based Organisation
FLO	Fairtrade Producer Organisation
FS	Feasibility Study
GAP	Good Agricultural Practises
GHS	Globally Harmonised System
GoM	Government of Malawi
IFC	International Finance Corporation
IPM	Integrated Pest Management
IPMP	Integrated Pest management Plan
LGB	Larger Grain Borer
MCPA	2-methyl-4-chlorophenoxyacetic acid (herbicide)
MFERP	Malawi Floods Emergency Recovery Project
MoAIWD	Ministry of Agriculture, Irrigation and Water Development
MRL	Maximum Residue Level
MSMA	Monosodium Methanearsonate (herbicide)
KRC	Korea Rural Corporation
PPEs	Personal Protective Equipment's
PMP	Pest Management Plan
POP	Persistent Organic Pollutants
PPRSD	Plant protection services
RYMV	Rice Yellow Mottle Virus
SUCOMA	Sugar Corporation of Malawi
SVIP	Shire Valley Irrigation Project
TN	Teretriosoma Nigrescens
ToRS	Terms of References
USA	United States of America
WB	World Bank
YSA	Yellow Sugarcane Aphid

## 1. INTRODUCTION

This report is a Pest Management Plan report (PMP) for the Shire Valley Irrigation Project (SVIP), prepared by the Ministry of Agriculture, Irrigation and Water Development with the help of BRLi (the Consultant).

This report is the Consultant's final version provided for public disclosure. However, it is likely that the Government of Malawi will update this report in response to further public and stakeholder comments as well as any new technical project information that may become available.

### PROJECT BACKGROUND AND RATIONALE

The Project consists on developing 42,500 ha of net area of land for gravity irrigated agriculture in the Lower Shire River Valley, in Malawi. The project will take place in two districts: Chikwawa and Nsanje districts.

*Figure 1-1 : Localisation of the studied area*





According to the Terms of References (ToRs), the Project rationale comes from the countries high dependence on rain-fed agriculture for food production. Due to uncertainties of rain-fed agriculture, the Government of Malawi intends to develop irrigated agriculture in the Lower Shire Valley on the West bank of the Shire River. The GoM has requested financial assistance from the World Bank (WB) and the African Development Bank (AfDB) for the preparation of proposed Shire Valley Irrigation Project (SVIP). Accordingly, the World Bank and African Development Bank are supporting the Government with the preparation of comprehensive studies required to appraise the technical feasibility, economic viability, and environmental and social sustainability of the SVIP.

#### THE AGRICULTURAL SECTOR-WIDE APPROACH

Malawi has been implementing the Agricultural Sector Wide Approach (ASWAp) since 2011 with the aim of increasing agricultural productivity, improving food security, diversifying food production to improve nutrition at household level, and increasing the level of household incomes realised by people residing in the rural areas. The ASWAp is a priority programme under the Malawi Growth and Development Strategy (MGDs) and its implementation is consistent with the Comprehensive African Agricultural Development Programme (CAADP) under New Partnership for Africa's Development (NEPAD). It is an investment framework that operationalizes commitments made by the GoM and its development partners in the agricultural sector as a whole.

The current ASWAp, which covers the period of 2011-2016, advocates for and drives strategic investment toward programmes and initiatives that fall under three distinct pillars, namely:

- food security and risk management;
- commercialization of agriculture, agro-processing, and market development; and
- sustainable agricultural land and water management.

These are complemented by two key support services: technology generation and dissemination; and, institutional strengthening and capacity building.

The ASWAp targets a minimum average growth rate for the agricultural sector of 6 percent per annum as well as raising annual household agricultural incomes from US\$280 to US\$600. Currently, the bulk of resources mobilized under ASWAP are channeled towards crop production (50-70 percent), leaving limited resources for other components of the ASWAp.

#### OBJECTIVE OF THE PROJECT

The Project objective is to provide access to reliable gravity-fed irrigation and drainage services, secure land tenure for smallholder farmers, and strengthen management of wetlands and protected areas in the Shire Valley.

#### OBJECTIVES OF THE ESIA

This assignment has to comply with the national policies regarding impact assessment as well as the World Bank triggered safeguard policies. Measures developed under this assignment will inform the Client and upcoming technical studies about ways to mitigate impacts and enhance positive effects of the Project. The ESIA is based on the Feasibility Study description of the Project.

#### OBJECTIVES OF THE PMP

The objectives of the PMP are to:

- To describe the existing and anticipated pest and diseases in the Shire Valley;
- To describe measures to fight or limit crop pests and diseases in the SVIP;

- To propose management options regarding these pests and diseases in the SVIP;
- To develop a plan on how to manage anticipated increased usage in pesticides resulting from agricultural expansion and intensification;
- To comply with the World Bank safeguard policy OP 4.09 - Pest Management and national regulations regarding the use of pesticides.

The World Bank Safeguard Policies – Pest Management ( OP 4.09) (see 3.1.2) describes a two-phase procedure for developing a PMP. The first phase of the plan - an initial reconnaissance to identify the main pest problems and their contexts (ecological, agricultural, public health, economic, and institutional) and to define broad parameters - is carried out as part of project preparation and is evaluated at appraisal. The second phase - development of specific operational plans to address the pest problems identified - is often carried out as a component of the project itself.

Accordingly, an initial reconnaissance by the Integrated Pest Management Specialist has been carried out involving (i) desktop review of available information, (ii) meetings with relevant national, and regional institutions, (iii) meetings with key informants in the project area. The results are presented in this report which is intended to meet the requirements for a Phase 1 Pest Management Plan for SVIP in terms of Bank procedures for project preparation.

The World Bank's Pest Management OP 4.09 covers the management of disease vectors as well as agricultural pests, while the TOR for the ESIA+PMP mentions Integrated Vector Management as part of the PMP. The discussion on integrated approaches to the effective and environmentally sound management of the potentially significant vectors for diseases such as malaria (*Anopheles* mosquitoes) and schistosomiasis (*Biomphalaria* snails) is part of a specific report within the Environmental and Social Management Plan (ESMP).

## 2. BACKGROUND INFORMATION ON THE PROJECT

### PRESENTATION OF THE PROJECT

As mentioned in the latest version of the Option Assessment report (Korea Rural Corporation May, 2016), the Project consists of:

- A water intake at Kapichira reservoir, the highest topographic point of the scheme, on the right bank of the Shire River, upstream from the training dike and the fuse dike, on the opposite side of the water intake of ESCOM for the hydropower station. ESCOM powerplant has a capacity of 132 MW. An environmental flow of 30-50m<sup>3</sup>/s is currently released from the dam spillway to sustain the Kapichira falls, important touristic attraction of the Majete Wildlife Reserve.
- The water intake will extract a certain amount of water from the Shire River (the reservoir) to distribute water by gravity to the scheme. The value is still to be decided, however, it will be around 50 m<sup>3</sup>/s. The following map shows the main Project features.
- Three canals:
  - A Feeder canal, also called Main canal 1, with a total length of 33.8 km (conveying water from the water intake),
  - The Supini canal, also called Main canal 3, with a total length of 10.7 km (previously called Illovo canal) mainly irrigating Phase I,
  - The Bangula canal, also called Main canal 2, with a total length of 88.0 km mainly irrigating Phase II but also some Zone in Phase I (before Lengwe National Park).

The project is made of several irrigated areas as shown in the figure next page: Phase 1 consists of three zones:

- Zone I-1: 9,631ha (total area, including access roads and right of ways)
- Zone I-2: 11,250ha (total area, which is made of Illovo estate)
- Zone A: 5,199ha (total area)

Phase 2 consists of three zones:

- Zone B: 9,925ha (total area, which is partly made of Illovo estate)
- Zone C: 10,749ha (total area)
- Zone D: 4,076ha (total area)

The total area is 50,830ha of land. The irrigation land covers 43,370ha (without road, canals and infrastructures).

The Feasibility Study (FS) for the Project is still in progress and will most likely be finalized after the ESIA. It is undertaken by Korea Rural Corporation in Joint Venture with Dasan Consultants co., LTD., GK Works Civil and Structural Engineers.

The latest available data from the Project are shown in the following figure.

Figure 2-1 : Layout of the irrigated scheme

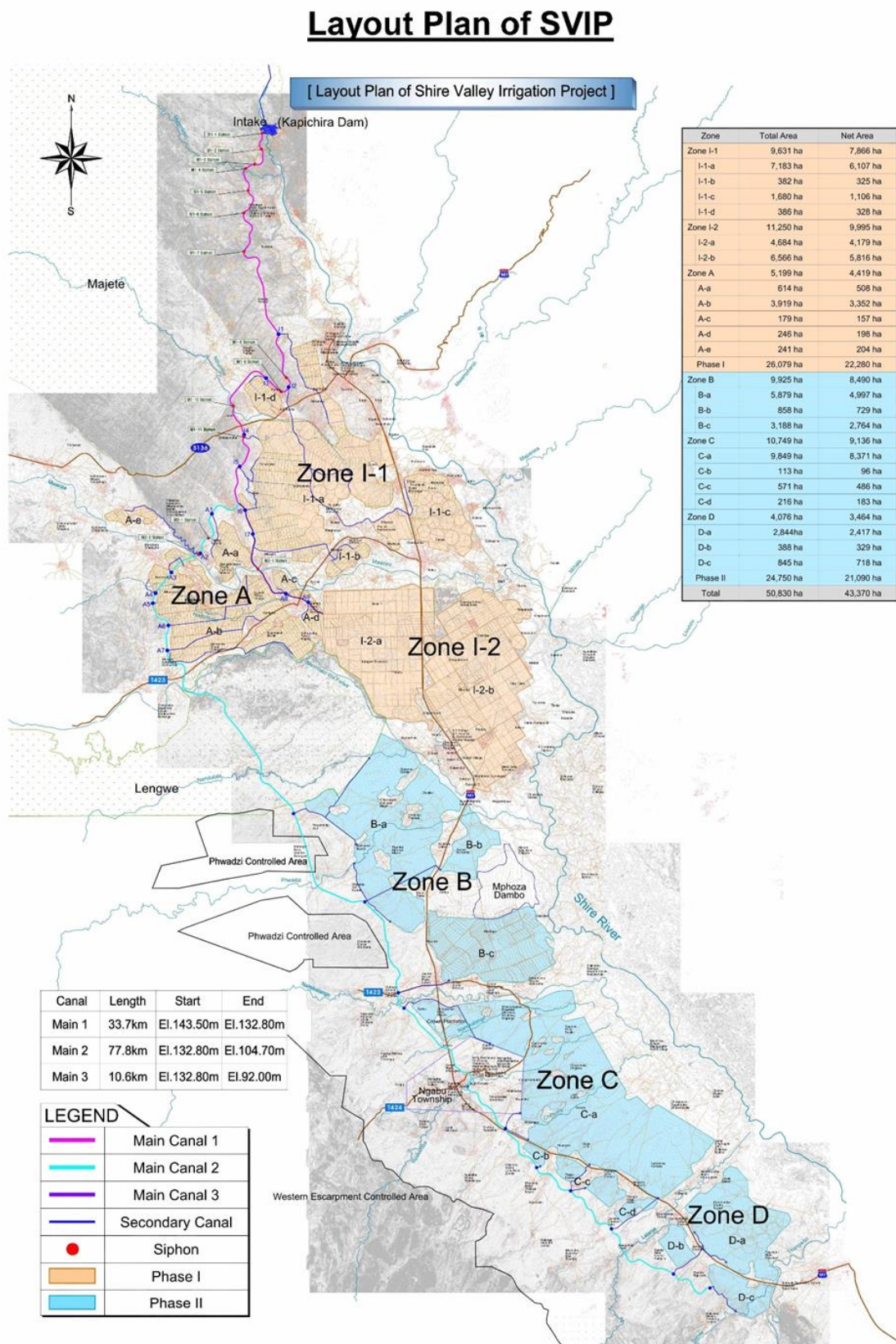

#### CURRENT IRRIGATED AREA: ILLOVO SUGAR LIMITED

Illovo Sugar (Malawi) Limited was initially incorporated in Malawi as a private company (The Sugar Corporation of Malawi (SUCOMA) Limited) on 31 May 1965 and then converted to a public company on 15 September 1997. The name was officially changed from SUCOMA to Illovo Sugar (Malawi) Limited on 11 November 2004. It is part of the Illovo Sugar group, which is the continent's biggest sugar producer and has extensive agricultural and manufacturing operations in six African countries.

Illovo Sugar (Malawi) Limited is the country's sole producer of sugar and plays a significant role in Malawian economy in general, providing permanent as well as seasonal employment for 10,000 people. Many local industries are dependent upon Illovo for their viability and employment created by these businesses provides an income base for many households. It further supports an estimated 3,700 people through various outgrower schemes by buying their crop. Illovo Malawi is the country's largest private-sector employer and the group generates valuable foreign exchange through export sugar sales.

Nchalo factory produces raw and refined sugar and also manufacturing value added speciality sugars. Over half of the sugar produced is sold into the local direct consumption market through the company's chain of distribution centres situated throughout Malawi and also into the local industrial market, 30% into markets in the European Union (EU ) and the United States of America (USA) with the remaining sold into regional African markets. Both milling operations produce molasses, a by-product of the sugar manufacturing process, which is currently sold as a fermentation raw material to the Ethanol Company and Presscane fuel alcohol distilleries in the area.

Illovo Nchalo sugarcane production area is irrigated from Shire River. The acreage under cultivation is 12,759 ha. Around Illovo production area, several outgrowers are also sugarcane providers for the sugar factory. The total surface under sugarcane in the Shire Valley is 15,757 ha. SVIP is planning to supply water by gravity irrigation from Kapichira reservoir, which is located in the upper region of the project area.

### **3. POLICY LEGAL AND INSTITUTIONAL FRAMEWORK OF INTEGRATED PEST MANAGEMENT PLAN**

This part is from the 'Malawi Floods Emergency Recovery Project (MFERP)', IPMP, sept 2015.

The use of integrated pest control measures in irrigation schemes has to adhere to various policies and laws in Malawi as well and World Bank Environmental Safeguard Policies. Examples of environmental related policies and laws in Malawi include Pesticide Act (2000), Pesticide Regulations (2002), National Environmental Policy (2004), Plant Protection Act among others. Operational Policy 4:09 (Pest Management) is the main World Bank Safeguard Policy which guides integrated pest management plan for projects which require pesticides.

The following paragraphs highlight requirements for adherences from various policies and legislation.

## 3.1 POLICIES

### 3.1.1 The National Environmental Policy (2004)

The National Environmental Policy focuses on the satisfaction of basic needs for humans and protecting the environment in the cause of development. The policy also recognizes the need to ensure food security and eradication of rural poverty through the promotion of production systems, technologies and practices that are environmentally sound. The policy has identified several environmental issues in the country. These are land degradation, water pollution, air pollution, loss of wildlife habitats, deterioration of aquatic systems and deforestation. The PMP as a planning tool shall be used to integrate environmental considerations in the decision making process in order to ensure sustainability. The plan will also address the following policy objectives with respect to environmental management in agriculture: i) to ensure sustainability, security, equitable and sustainable use of natural resources; ii) to prevent and control degradation of land, water, vegetation, and air; iii) to conserve biological diversity of the unique ecosystems the country; iv) to raise public awareness and understanding of the essential linkages between environment and development; and, v) to promote individual and community participation in environmental action.

### 3.1.2 World Bank Safeguard Policies – Pest Management Policy ( OP 4.09)

The policy supports safe, affective, and environmentally sound pest management. It promotes the use of biological and environmental control methods. A preferred solution is to use Integrated Pest Management (IPM) techniques and encourage their use in the whole of the sectors concerned. The policy also aims at assisting proponents to manage pests that affect either agriculture or public health, supports a strategy that promotes the use of biological or environmental control methods and reduces reliance on synthetic chemical pesticides. Operational Policy (OP 4:09) recommends that integrated pest management plans be used for World Bank funded agriculture related projects. The approaches include as biological control, cultural practices, and the development and use of crop varieties that are resistant or tolerant to the pest. The policy calls for assessment of the nature and degree of associated risks, taking into account the proposed use and the intended users for procurement of any pesticide in Bank-financed projects. It is a requirement that any pesticides that will be used, will be manufactured, packaged, labelled, handled, stored, disposed of, and applied according to standards acceptable to the World Bank. This plan has included internationally accepted guidelines on storage, labelling, application and disposal of obsolete pesticides.

In line with requirement under this policy, this Integrated Pest Management Plan has included measures for storage of pesticides, distribution of pesticides, application of pesticides on irrigation schemes and measures on disposal of obsolete pesticides. In addition, the plan includes recommended guidelines on protective clothing /equipment for those farmers to be involved in application of pesticides on irrigation schemes. Funds from the World Bank for project will not be used to procure pesticides for use on the irrigation schemes. Government of Malawi will ensure effective integrated pesticide management plans are in place for all irrigation schemes to be rehabilitated under this project.

## 3.2 LEGAL FRAMEWORK

### 3.2.1 The Pesticide Act (2000)

Pesticide Act provides for the life-cycle management of pesticides, regulating the manufacture, formulation, importation into and exportation from the country, transport, storage, distribution, sale, use and disposal of pesticides and to regulate other matters connected thereto. This Act establishes the **Pesticides Control Board (PCB)** which is responsible for monitoring the trade and use of pesticides, and collecting statistical and other information concerning the import, export, manufacture, distribution, sale and use of pesticides, about pesticide residues and safe use. The act prohibits the importation, manufacturing, formulating, transportation, distribution, exportation or sell of banned, obsolete pesticides and any other pesticide banned or severely restricted in the country of origin under any circumstances within the country or any pesticide for which is not in the category/group currently under use. In relation to Integrated Pest Management Plan, Pesticide Control Board recommends availability of safer alternatives to existing pesticides as per latest global research and development without compromising the importation of biological control agents as allowed in the biological control agents protocol developed within the Plant Protection Act (1974). Regarding the **ADDs**, they have limited involvement in the assessment and regulation of pesticides. ADDs can check, and report, but not impound any illegally used pesticides.

### 3.2.2 Pesticides Regulations (2002)

Pesticide Regulations were put in place to guide on the implementation of provisions of Pesticide Act. The objectives include – (i) to ensure the effectiveness of pesticides used in Malawi for the production of food and for the protection of public health and safety; (ii) to protect against possible harmful effects of pesticides including: (a) impairment of the health of people handling pesticides or using or consuming products or substance treated with pesticides; (b) impairment of the health of domestic animals including honey bees from direct application or pesticides or from the consumption of plant or animals treated with pesticides; (c) damage to cultivated plants from direct application or pesticides or from persistent soil residues and (d) damage to the natural environment including impairment of the health of wildlife and contamination of waterway lakes and other water bodies.

### 3.2.3 The Environment Management Act (60:02)

In relation to the management of dangerous materials and processes, of which agricultural chemicals may fall, the Minister has the power to make regulations pertaining to persistent organic pollutants (POP) and pesticides issues, to ensure that they are in compliance with the Stockholm Convention on POP of 2001 and Rotterdam Convention on the Prior Informed Consent Procedure for Certain Hazardous Chemicals and Pesticides in International Trade of 1998. Furthermore, the Minister has the powers to make regulations regarding the prevention and control of pollution. This mainly relates to the discharge of hazardous substances such as chemicals or mixtures containing oil in water or any other segment of the environment, except in accordance with guidelines prescribed under this Act or any other written law. In this context, services that relate to the regulation of agricultural chemicals in the Ministry of Agriculture, Irrigation and Food Security shall be at the forefront to ensure the judicial use of pesticides in agriculture.

According to this act, The Minister may, in consultation with the Minister responsible for agriculture, classification make rules for classifying pesticides and hazardous substances, and for determining of pesticides their toxicity and hazardous substances. The rules may make provision:

- (a) requiring the registration, labelling and packaging of pesticide and hazardous substances;

(b) for measures for controlling the manufacture, importation and exportation of pesticides and hazardous substances;

(c) for the distribution, storage, handling and transportation of pesticides and hazardous substances;

(d) for monitoring the impact of pesticides and hazardous substances and their residuary effect on public health, the environment and natural resources;

### 3.2.4 The Water Resource Act (2013)

The Act provides for institutional and legal integrated pest management plan for sustainable management and development of water resources; outlines principles for water resources management; for prevention and control of water pollution; and provides for participation of stakeholders and general public in implementation of the National Water Policy (2005). Its main objective is to ensure that the country's water resources are protected, used, developed, conserved, managed and controlled in ways that meet the basic human needs of present and future generations, prevent and control pollution of water resources and protect biological diversity especially the aquatic ecosystems. The act stipulates that any owner or occupier of land whose activities or processes are likely to cause pollution of a water source, shall take all reasonable measures to prevent any such pollution from occurring, continuing or recurring. Failure to comply with such a directive, National Water Resources Authority may take measures as it considers necessary to remedy the situation. In this context, the IPMP will strive to comply with the provisions of the Act.

### 3.2.5 Plant Protection Act

This Act has made provisions for consolidation of plant protection to prevent introduction and spread of harmful organisms, to ensure sustainable plant and environmental protection, to control the importation and use of plant protection substances, to regulate export and imports of plant and plant products and ensure fulfilment of international commitments, and to entrust all plant protection regulatory functions to the government and for matters incidental thereto or connected therewith. Agriculture Research Stations have Gene Bank Divisions which coordinate the regulatory functions on protection of plants in Malawi. In relation to Integrated Pest Management Plan, Plant Protection Act, highlights that importation of biological control agents is not allowed unless under the prescribed permit by the Ministry responsible for Agriculture.

## 3.3 INSTITUTIONAL FRAMEWORK

Malawi, like most of the countries that rely on agriculture, uses considerable amounts of pesticides as one way of combating pest problems. Pesticides used in Malawi include insecticides, fungicides, herbicides, nematicides, acaricides and rodenticides. Other products such as growth regulators, repellents, molluscicides and parasiticides are also used. In addition, some botanicals have been released.

The major importers of pesticides in Malawi are:

- Farmers Organizations Limited;
- Chemicals World;
- Export Trading Group;
- Osho Chemicals;
- Agricultural Trading Company (A.T.C);
- Fordhan Limited.



Malawi shares borders with Zambia, Mozambique and Tanzania and this geographical proximity to these countries facilitates both trade and accessibility to unregulated and illegal chemical pesticides especially for the districts close to these bordering countries.

**The office of the Registrar** is mandated to ensure that all registered and licensed pesticide dealers conform to the regulations for safe handling of the pesticides. Pesticides dealers should follow the “safety” guidelines on transportation, distribution, application, storage and disposal of pesticides.

**The Pesticide Control Board (PCB)** must ensure that all stakeholders observe safe handling of pesticides. The Registrar is mandated to make frequent checks in all premises where pesticides are stored to ensure safety. The Registrar is also mandated to take stock of obsolete pesticides in all premises. The PCB advises the Malawi Government on how to dispose of obsolete stock. This involves collecting obsolete stocks from all premises and arranging for disposal.

**The MoAIWD** and the respective **Agricultural Development Divisions (ADD's)** provide the technical assistance to the Farmer Groups and also policy guidance.

**Agricultural sector departments** have the national mandate in the implementation of crop and livestock protection and pest management research.

**Agriculture Services Providers** and **NGOs** are providing services to farmers and improving agricultural productivity, environmental management and rural health matters.

**Environmental Affairs Department.** Environmental Affairs Department established under Environment Management Act has responsibilities of: i) advising and implementing policies of the government on the protection and management of environment; ii) coordinating activities related to the environment; iii) ensure that environmental concerns are integrated into the development planning and project implementation in a way which protects the environment; iv) prepare and coordinate the implementation of environmental action plans at the national and local levels; and, v) ensure that environmental standards are environmentally sound.

## 4. CURRENT PESTICIDE USES, CHALLENGES AND IPM AWARENESS IN MALAWI

The Malawian agricultural sector is characterised by a dualistic structure: a high input, high productivity estate sector, and a low-input, low-productivity smallholder sector which has received little investment or encouragement to engage with export markets over the last 35 years.

Malawi, like most of the countries that depend on agriculture, uses considerable amounts of pesticides as one way of combating pest problems. Pesticides used in Malawi include insecticides, fungicides, herbicides, nematicides, acaricides and rodenticides. Other products such as growth regulators, repellents, molluscicides and parasiticides are also used. In addition, some botanicals have been released.

The major crops grown in Malawi, for which pesticides are used, include tobacco, sugarcane, coffee, maize, cotton and tea. Pesticides are used for these crops to prevent and control various pests and diseases that attack them.

Malawi does not manufacture pesticides. This means that all pesticides used in the country are imported. The most commonly used products are insecticides, followed by herbicides, fungicides and rodenticides. Herbicides are mostly used in sugar plantations, whereas fumigants are mostly dominant in the tobacco industries. Insecticides are mostly used in field crops, particularly maize.

**The ADDs have limited involvement** in the assessment and regulation of pesticides. ADDs can check, report, but not impound any illegally used pesticides. With limited resources, government does not have the capacity to fully regulate pesticides use in Malawi and therefore involvement of ADDs would complement government's efforts. Incessant expansion of Malawi government's regulatory duties and responsibilities conducts to stretch its finances and resources too thin and to seriously **dilute its role and capacity of chemical pesticide regulation**; and then renders it ineffective.

There is a disparity between the challenges as perceived by farmers and those expressed by officials from agricultural sector. Some of the general challenges are that Malawi does not manufacture pesticides and in addition, **Malawi does not have ultimate pesticides disposal facilities** (such as pesticide incinerators). Others challenges are:

- **The use of unregulated pesticides** as Malawi shares borders with Zambia, Mozambique and Tanzania with difficulties to control chemicals coming from those countries. The consequences are: (i) a threat of the introduction of highly toxic substances into the environment, putting human beings, plant and animals at risk; (ii) development of pest resistance and economic loss on the part of the farmers for using substandard chemicals.
- **The use of expired pesticides.** There is indiscriminate use of expired chemical pesticides by farmers; a problem emanating from shared negligence between the farmers and chemical pesticide marketers. Both parties contribute to the situation partly due to ignorance. Unlicensed chemical pesticide marketers also contribute to the proliferation of expired chemicals.
- **Lack of appropriate skills.** Control of pesticide use requires an interdisciplinary approach, due to the breadth and depth of the subject. Junior officers usually lack appropriate training in pesticides management.
- **Inadequate protective gear.** A combination of ignorance of the potential risks associated with chemical pesticides, with the lack of sufficient funding, imposes formidable strains on the safety methods of chemical pesticide application.
- **Farmers' attitude.** There is a misinformed approach amongst farmers, where chemical remedies for pests are sought in the first instance.
- **Out-dated** Crop Policy, Plant Protection Act, Livestock Policy and Animal Disease Act.

Integrated Pest Management requires wider knowledge unlike traditional programs. Managing pests with less pesticide requires a strong working knowledge of pest biology and behaviour, current pest control technologies and practices, climate and its effects on pest proliferation, greenhouse and storage structural characteristics and staff behaviour. Without this knowledge, it will be difficult, if not impossible, to prevent infestations. We can conclude, considering the elements mentioned above, that a strong capacity building plan will be needed to bring stakeholders up to the challenges.

## 5. EXISTING AND ANTICIPATED PESTS AND DISEASES PROBLEMS ON IRRIGATION SCHEMES

### 5.1 CURRENT IRRIGATED CROPS AND FUTURE CROPPING PATTERN

With the implementation of SVIP, the surface under irrigation will increase from around 15,000 ha today to 42,500 ha after extension. This PMP report assesses the impact of this increase (almost 3 times the current irrigated area) on pests and diseases of irrigated crops.

The preliminary recommended list of crops to be included in the cropping programme for the Shire Valley Irrigation Project, according to the Study on the Formulation of the Agricultural Development Planning Strategy (AgDPS), is as follows:

- *Sugar cane*: Sugar cane is the most widely grown commercial crop in the area covering about 15,000 ha.
- *Cotton*: The recent pronouncements by government that it will allow growing of Bt cotton (genetically modified cotton) should reduce input costs and make cotton more viable.
- *Maize*: Malawi is currently experiencing food shortage challenges because of the erratic rainfall. Growing maize in the Shire Valley under irrigation will supplement the dryland maize ; excess may be exported.
- *Soya beans*: Based on information from Malawi Investment and Trade Centre there is growing demand for soya beans locally and in the region.
- *Cassava*: Cassava can be used in starch, livestock feed and ethanol production.
- *Pigeon pea*: There is great demand for pigeon peas from Asian countries.
- *Dry beans (Phaseolus vulgaris)*: Beans is consumed intensively locally and can be exported to countries in Eastern and Southern Africa.
- *Chilies*: Malawi is famous for its bird's eye chilies and there is export demand.
- *Tomatoes*: The tomatoes recommended for the SVIP are the oval shaped processing type that can be used for making juice and pastes.
- *Tropical fruits (oranges, mangoes and bananas)*: fruits should lead to establishment of processing factories and export of fresh fruit.

The 'Volume 1: Draft Agricultural Development Planning Strategy Report, Formulation of the Agricultural Development Planning Strategy, July 2016, PWC' proposed a cropping pattern for the extension of irrigated area which is presented in the table below.

**Figure 5-1 : Proposed irrigated cropping pattern**

Option	Year 1		Year 2		Year 3	
	Summer	Winter	Summer	Winter	Summer	Winter
Option 1	Cotton	Beans	Cotton	Beans	Cotton	Beans
	Soya beans	Maize	Soya beans	Maize	Soya beans	Maize
	Sugarcane	Sugarcane	Sugarcane	Sugarcane	Sugarcane	Sugarcane
Option 2	Cotton	Beans	Cotton	Beans	Cotton	Beans
	Pigeon pea	Maize	Pigeon pea	Maize	Pigeon pea	Maize
	Sugarcane	Sugarcane	Sugarcane	Sugarcane	Sugarcane	Sugarcane

Source: Volume 1: Draft Agricultural Development Planning Strategy Report, Formulation of the Agricultural Development Planning Strategy, July 2016, PWC

#### CROPS FOR IRRIGATION SCHEME DESIGN PURPOSES

The Technical Feasibility Study needs to estimate design requirement for the whole project area including the existing large scale sugarcane plantations. There is need to select appropriate crops that will ensure that when changes are made, there are no major water shortages. For this reason, crops that have low water requirements such as sorghum and millets may not be appropriate for design purposes. Therefore, this PMP proposes crops that have a relatively high water requirements for design purposes and not just the first three years of the project. The proposed crop allocations are presented in the Table below.

**Table 5-1: Percent area allocated to each crop in summer and winter**

Crop	Percent area in summer	Percent area in winter	Comments
Sugarcane	44	44	Currently occupying 37 percent
Tropical fruits	6	6	Including oranges, mangoes and bananas
Cotton	30	-	Currently a summer crop and recommended to remain a summer crop under irrigation.
Soya beans	20	-	
Maize	-	30	Higher yields in winter, summer temperatures too high.
Beans ( <i>Phaseolus vulgaris</i> L.)	-	20	Does best in winter, summer temperatures too high.
<b>Total</b>	<b>100</b>	<b>100</b>	

Source: Volume I: Draft Agricultural Development Planning Strategy Report, Formulation of the Agricultural Development Planning Strategy, July 2016, PWC

**Note:** except for sugarcane, percent allocations to each crop can change every season in-line with market conditions.

The Table below presents cropping cycles showing time of planting, vegetative growth and harvesting for some selected crops. There will be a very tight change over from the summer to winter crops or vice versa. To overcome this bottleneck there is need to have modern heavy machinery and equipment.

**Table 5-2: Crop cycles of potential crops for the Shire Valley Irrigation Project**

Annual Crops	Hot and Wet Season			Cold / Dry Season					Hot & Dry Season		Hot & Wet Season	
	Jan	Feb	Mar	Apr	May	June	July	Aug	Sept	Oct	Nov	Dec
Cotton	■	■	■	■	■						■	■
Soya beans	■	■	■	■								■
Pigeon Pea	■	■	■	■	■							■
Maize				■	■	■	■	■	■	■		
Dry beans					■	■	■	■	■	■		
Tropical fruits	■	■	■	■	■	■	■	■	■	■	■	■
Sugar cane	■	■	■	■	■	■	■	■	■	■	■	■

■ Sowing ■ Growing ■ Harvesting

Source: Volume I: Draft Agricultural Development Planning Strategy Report, Formulation of the Agricultural Development Planning Strategy, July 2016, PWC

Taking into account both the Agricultural Development Planning Strategy and the Technical feasibility Study, this PMP has selected the following crops to be assessed:

- **Sugarcane:** it is the main crop to be developed after extension of irrigation. The sugarcane plantation will be developed by Illovo and outgrowers;
- **Cotton:** it is the main cash crops for small holder farmers;
- **Tropical fruits:** including oranges, mangoes and bananas;

- Cereals: maize and sorghum are major staple-food for the region and there is a need to increase the production. Irrigation will be a mean to secure production from climatic hazards;
- Rice: vertisols are largely present in the studied area and are very good soils to develop irrigated rice;
- Beans: this legume is widely grown by farmers in the studied area. It can rotate with cereals;
- Horticultural crops: there is an option for crop diversification with leafy vegetables, tomato and onion.

The chapters below present the situation of pests and diseases in the Shire Valley for these main crops.

## 5.2 MAJOR PESTS AND DISEASES OF SUGARCANE

Commercial sugarcane is normally grown as a long-term monoculture. Crop pests thrive where a host plant is abundant in both time and space, and where controlling factors are absent or limited. Hence, cultivating sugarcane, year after year, over large, often contiguous areas can lead to widespread crop loss, and even complete crop failure if no attempt is made to contain the pests. Thus, identifying important pests, and knowing what to do about them, is vital for the sustained production of sugarcane.

### 5.2.1 Yellow sugarcane aphids

#### 5.2.1.1 Description

Yellow sugarcane aphid (YSA), *Sipha flava*, is a fairly small, dull to bright yellow aphid with short legs, antennae and mouth parts.

Figure 5-2 : Yellow Sugarcane Aphids



Source: Gregg S. Nuessly, University of Florida

This aphid takes 2 to 3 weeks to develop to the adult stage at which point it can produce 3 to 5 nymphs per day for another 2 to 3 weeks. Winged forms of the aphid are produced under crowded conditions when plant quality is beginning to be significantly affected.

Yellow sugarcane aphid feeding leads to premature yellowing and death of sugarcane leaves. Feeding on very young plants leads to reduced growth and tillering. YSA feeding results in longer, faster growing leaves and internodes, but also thinner, lighter stalks with shorter node lengths and widths. Prolonged feeding by large populations of YSA can cause plant death. Sugarcane leaf and node lengths approach sizes of uninfested plants after YSA are removed, but node diameter remains lower on previously infested stalks. Sugarcane plants do not compensate for early-season YSA damage. Such damage ultimately results in lighter stalks that contain less sugar. Severely damaged stalks that survive have narrow internodes near the soil surface that frequently break later in the season due to strong winds and tropical weather storms.

**Figure 5-3 : Yellow Sugarcane Aphids infestation in Nchalo**

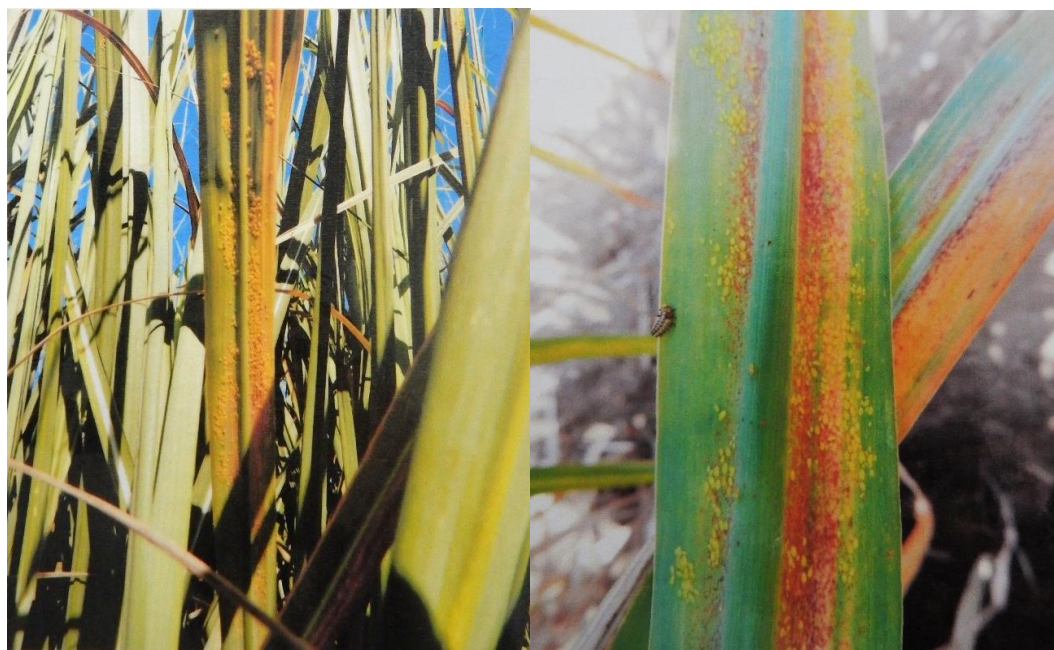

Source: Illovo.

Rain and natural enemies, including 10 species of ladybird beetles, several species of flower flies, green lacewings and brown lacewings, can greatly reduce populations, but this may not occur before the aphids have caused plant damage. Aphids reproduce quickly and speedily build to numbers too numerous to count for sampling purposes. Leaf damage symptoms appear to be a good indicator of season-long effects on growth and yield and works without having to count aphids. Leaves with <50% green tissue can be quickly counted and averaged over an area to compare long term effects of YSA feeding with the relative size of the infestation. An infestation that leaves just four leaves beneath the top visible dewlap leaf with more than 50% green tissue is still enough to reduce sugar content at harvest. This means an average of 2 to 3 leaves with >50% damage early in the season will significantly reduce yield. Significantly greater yield reductions occur with each additional pair of leaves showing >50% YSA damage.

Figure 5-4 : Insects predators of Yellow Sugarcane Aphids

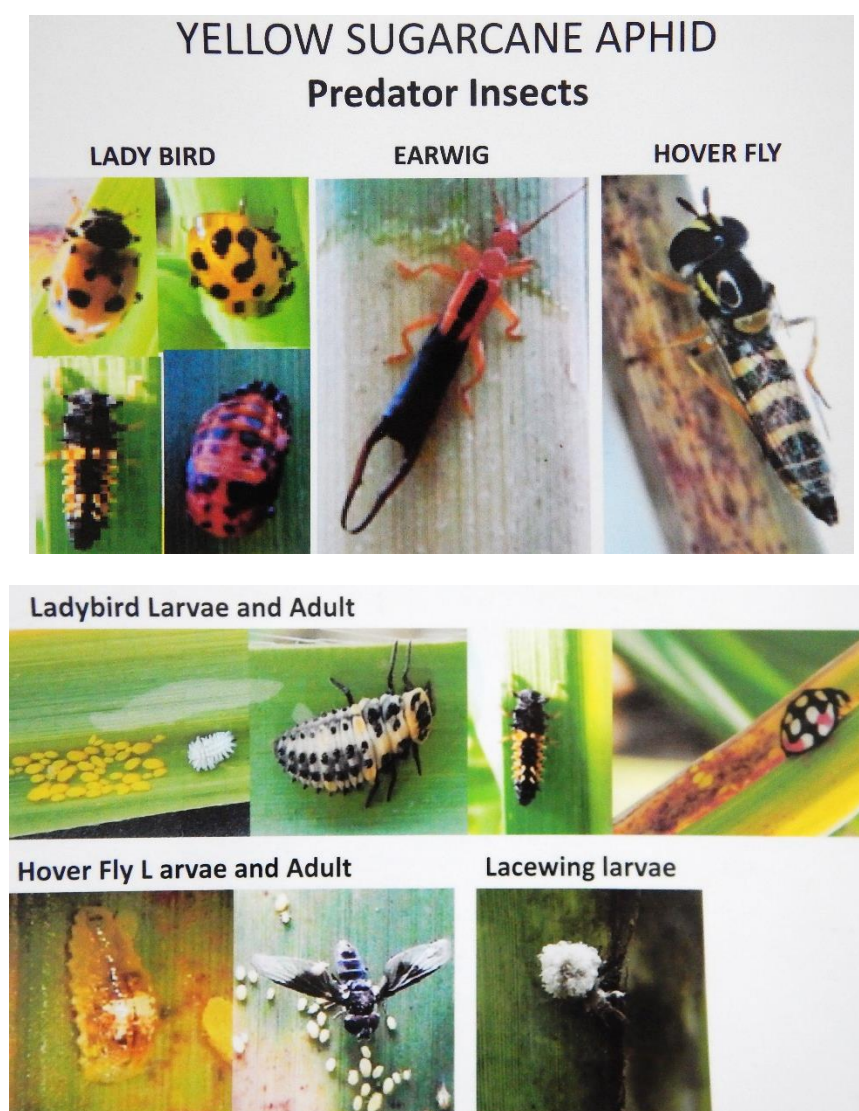

Source: Illovo.

### 5.2.1.2 Importance in the Shire Valley

YSA is a new sugarcane pest in the Shire valley. The first observations of YSA was in 2013 and it seems that the aphids came from Swaziland. The origin of the first introduction of this pest in Malawi is not known yet.

In few years, YSA has become a major pest in the Shire valley. Massive infestation occurs on plantation and on young ratoons. Loss in yield of infested field can reach more than 30%. Some fields with new plantation have already been completely destroyed by YSA.

The aphids are potential vectors of the sugarcane mosaic virus. This virus is not present yet in the Shire valley but a particular attention should be given to this eventuality of the introduction of mosaic virus.

### **5.2.1.3 Current control practises**

The agricultural department of Illovo Estate has implemented a survey observation system for aphids. Regular visual controls are done in the fields.

In case of infestation, chemicals are spread to kill the aphids. The chemicals used are cypermethrin and imidacloprid. The spraying is usually aerial. It can also be done with knapsack sprayer, especially for the young plants in a new plantation.

Illovo Estate is also working on biological method to control aphids. A PhD student is working on the identification of an entomopathogenic fungi efficient on YSA. An entomopathogenic fungus is a fungus that can act as a parasite of insects and kills or seriously disables them. Much hope relies on this method as it will be an organic solution to control this pest.

Note that Kasinthula Cane Growers Ltd became certified Fairtrade (FLO) as a Producer Organisation in 2004. In the Fairtrade standards harmful chemicals are prohibited.

## **5.2.2 Termites**

### **5.2.2.1 Description & Importance in the Shire Valley**

Termites are common pests of sugarcane in many countries. They occur in colonies as different castes: workers, soldiers and reproductives, including a very large, wingless, egg-laying queen. The nests are below ground and may be some distance from cane fields. Damage is caused by the workers feeding on newly planted setts, the base of the stalks and tissues inside the stalks. Dry conditions exacerbate the problem.

Termites are mainly a problem for outgrowers, to a lesser extent for Illovo Estates. This is mainly explained by a routine control against this pest at Illovo Estates when the problem is treated more occasionally by outgrowers.

### **5.2.2.2 Current control practises**

The common practise to control termites in the Shire Valley is to dig up the mound and kill the queen with chemical. The chemical used is Fipronil.

## **5.2.3 Rodents**

### **5.2.3.1 Description & Importance in the Shire Valley**

Rodents, particularly the multimammate shamba rat, *Mastomys natalensis*, are major pests of sugarcane and food crops in general. The rodents chew the stalks exposing the internal tissues to infection by bacteria and fungi, which reduces sucrose content, and the stalks may break.

### **5.2.3.2 Current control practises**

There is no specific method currently used in the Shire Valley. No chemicals are used and no specific practises.



## 5.2.4 Red spider mite

### 5.2.4.1 Description & Importance in the Shire Valley

The red spider mite, *Oligonychus indicus* is a harmful pest of sugarcane. Feeding of this mite causes the appearance of reddish spots which increase with the severity of attack. These spots later coalesce to form large red patches and spread on the leaf surface to turn the colour of the leaf red.



Source: [www.agric.wa.gov.au](http://www.agric.wa.gov.au)

This pest has been mainly mentioned by outgrowers. The red spider mite is not a problem at Illovo Estates.

### 5.2.4.2 Current control practises

The outgrowers conduct field survey with regular visual controls in the fields. In case of infestation chemical spraying is done with Agromectin (Abamectin 18g/L).

## 5.2.5 Other insects

Other insects are present in the Shire Valley but they are not considered as problems such as thrips, borers, locust and white grubs. In case of infestation, chemicals are sprayed. The main chemical used is chlorpyrifos.

## 5.2.6 Rust

### 5.2.6.1 Description & Importance in the Shire Valley

Orange rust is caused by a fungus, *Puccinia kuehnii*. Rust can be easily recognized from the characteristic appearance of the spore-bearing pustules (sori) on the undersurfaces of the leaves. It spreads by means of wind-blown and rain-splashed spores produced in the pustules on the leaves.

### 5.2.6.2 Current control practises

Rust is present in the sugarcane fields only in winter. There is no rust during the hot and dry summer conditions.

There is no curative practises for rust in the Shire Valley. The only action is to prevent dissemination of the fungus. Hot Water Treatment is done for the seedcane to eliminate the fungus before plantation. Rust is also controlled by the planting of resistant varieties.

## 5.2.7 Smut

### 5.2.7.1 Description & Importance in the Shire Valley

Smut is caused by a fungus, *Ustilago scitaminea*. Infected stalks often develop long, whip-like, spore-bearing structures (called 'smut whips') from the apical meristems or from the lateral buds. The whips are initially covered by a silvery-white membrane; this soon deteriorates to expose the black fungal spores. Infected plants may have a grass-like appearance due to the dense production of tillers.

### 5.2.7.2 Current control practises

Smut is a major problem for sugarcane in the Shire valley. It spreads by wind-blown spores and by the planting of infected seedcane.

The control of the fungus is done by:

- using of resistant varieties.
- using healthy seedcane (Hot Water Treatment eliminates smut from seedcane).
- roguing infected plants from nurseries.
- roguing infected plants from fields.

## 5.2.8 Pokkah Boeng

### 5.2.8.1 Description & Importance in the Shire Valley

Pokkah Boeng was originally described in Java, and the name is a Javanese term denoting a malformed or distorted top. It is caused by a complex of fungal species within the genus *Fusarium*. The disease is present in most, if not all, sugarcane producing areas of the world. Pokkah Boeng may cause serious yield losses in commercial plantings.

The initial symptoms of the disease are chlorotic areas at the base of young leaves, followed by distortion (wrinkling and twisting) and shortening of affected leaves. In severe cases, death of the stalk will occur.

### 5.2.8.2 Current control practises

Pokkah Boeng is present in the Shire valley. The only practises to control this disease is to use resistant varieties and to use clean seedcane (Hot Water treatment).

## 5.2.9 Weed control

Weed control is a necessity in sugarcane production if adequate yields are to be obtained, as yield reductions as high as 50 % can be experienced without weed control in plant cane. Although control measures such as hand hoeing and mechanical cultivation were widely practiced in the past, with the discovery of chemicals that could selectively control some plants and not others, the use of herbicides for weed control increased quickly and has become a major component of most weed control programs in sugarcane.

The table below presents the main weeds in sugarcane in Shire valley and their control practises.

**Table 5-3 : Main weeds in sugarcane fields and control practises**

Name of main weeds	Control practises	Name of chemicals used
Rottboellia cochinchinensis	Chemical spraying (Pre/Post) + hand weeding	Pendimethalin, hexazinone, Metribuzin+Chlorimuron, ametryn
Cynodon dactylon	Chemical spraying (Post)	Glyphosate, Butachlor, ametryn
Portulaca sp.	Chemical spraying (Post)	MCPA
Ipomea sp.	Chemical spraying (Post) + hand weeding	Triclopyr, MSMA
Cyperus sp.	Chemical spraying (Post)	Glyphosate

### 5.2.10 Chemical ripening

A range of chemical ripeners are available for use on specific cultivars, mainly on irrigated well grown and managed immature upright cane in the early or late season. Chemical ripeners are used to improve cane quality, milling efficiency, reduce transport costs and facilitate management.

Chemical ripening is practised by Illovo Estates by aerial spraying of Fusilade (fluazifop-P-butyl).

## 5.3 MAJOR PESTS AND DISEASES OF COTTON

Cotton is the main cash crop for small holder farmers in the Shire valley. Apart from providing cash incomes to farmers, processed cotton seeds provides valuable raw material for the manufacturing livestock and livestock feeds.

### 5.3.1 Weeds

It is extremely important to keep cotton free of weeds between planting and flowering. If weeds are left to compete with the crop during this period, very low yields will be obtained.

The main weeds are:

- Wild finger millet (*Eleusine indica*), Kapinga (*Cynodon dactylon*), herringbone grass (*Urochloa panicoides*), buffalo grass (*Panicum spp.*) and wild oat (*Avena fatua*);
- *Commelina benghalensis*, *Nicandra Physaloides*, *Bidens pilosa* and *Amaranthus sp.*;

Control of these weeds is done in the Shire Valley by frequent manual weeding and use of systemic herbicides such as glyphosate. Pre-emergence herbicides are also used like acetochlor (Harness EC).

### 5.3.2 Insects

Cotton has the highest insect pest load of all crops grown in Malawi. Consequently, insect pests are the largest single factor limiting cotton production in the area. Insects pests of economic importance are:

- African bollworm (*Helicoverpa armigera*)
- Spiny bollworm (*Earias biplaga* WIK and *E. insulana* Boisd)
- Red bollworm (*Diparopsis castanea* Hmps)
- Pink bollworm (*Peetinophora gossypiela* Samnd)

- Red spider mite (*Tretanychus spp.*)
- Cotton strainers (*Dysdercus spp.*)
- Jassid (*Jacobiella fascialis Jac*)
- Aphid (*Aphis gossypii Glov*)
- Termites (*Hodotermes spp.*)
- Elegant grasshopper (*Zonocerus elegans Thnb*)
- Cotton psyllid (*Paurocephala gossypia Russe*)
- Other general leaf eaters.

These can effectively be controlled by planned use of pesticides and good cultural practises.

The table below presents the recommended of choices of pesticides by the government to be used for chemical pest control in the Shire Valley.

**Table 5-4: Choice of pesticides in relation to pest species and crop growth stage of cotton**

Growth rate	Pest species	Action threshold levels	Pesticide	Rate*
Vegetative (3-6 weeks after emergence)	Jassid Psyllid Elegant grasshopper Semihopper Red bollworm Harvester termite	2 nymphs per leaf - When abundant - - When active	Carbaryl 85 Wp Profenofos 50 EC Triazophos 40 EC Seed plus 30 WS Cruiser extra 352 FS Thunder 145 SQ-TEQ	85g 40ml 75ml 5kg/kg seeds 5g
	Aphid Red spider mite	Present on 6 plants out of 24 When present	Dimethoate 20 WP Dimethoate 40 EC Triazophos 40 EC	34g 17ml 75ml
Squaring to flowering (6-10 weeks after emergence)	Red bollworm Spiny bollworm Psyllid Jassid	When eggs are found - - 2 nymphs	Carbaryl 85 WP Profenofos 50 EC Triazophos 40 EC	85g 40ml 75ml
	Aphid Red spider mite	Present on 6 plants out of 24 When present	Dimethoate 20 WP Dimethoate 40 EC Triazophos 40 EC	34g 17ml 75ml
Peak flowering (10-13 or 12-15 weeks after emergence)	African bollworm Red bollworm Spiny bollworm	Present on 6 plants out of 24	Use anyone of the following: Lambda-cyhalothrin 5 EC Cyfluthrin 5 EC Fenvalerate 20 EC Deltamethrin 2.5 EC Cypermethrin Thiodicarb 375 FW	12ml 12ml 15ml 10ml 72ml
	Aphid Red spider mite	Present on 6 plants out of 24 When present	Dimethoate 20 WP Dimethoate 40 EC Triazophos 40 EC	34g 17ml 75ml
	Red bollworm Cotton strainers	When eggs are found When abundant	Carbaryl 85 WP Profenofos 50 EC Triazophos 40 EC	85g 40ml 75ml

Boll formation to boll maturity (beginning 13 to 15 weeks after emergence)	Aphid	Present on 6 plants out of 24	Dimethoate 20 WP	34g
	Red spider mite	When present	Dimethoate 40 EC Triazophos 40 EC	17ml 75ml
Boll opening	Cotton strainers	When abundant	Carbaryl 85 WP	85g
	Dusky strainers ( <i>Oxycaremis spp.</i> )	When present	Profenofos 50 EC Triazophos 40 EC	40ml 75ml
	Aphid	Present on 6 plants out of 24	Dimethoate 20 WP Dimethoate 40 EC Triazophos 40 EC	34g 17ml 75ml

Source: Guide to Agricultural Production and natural Resources Management in Malawi, Ministry of Agriculture and Food Security, 2003.

\*Rate (weight or volume) of pesticide to be mixed with 14 litres of water for Knapsack sprayer.

The cropping calendar from the SVIP Agricultural Strategy proposed to grow cotton during the hot & wet season (Oct-March). This is also the season where rainfed cotton is traditionally grown in the valley. Thus irrigating cotton during this period where cotton is present everywhere, will not increase pressure of pest for cotton.

Contrariwise, the crop rotation proposed for cotton in the SVIP Agricultural Strategy can have a strong negative impact on pest pressure. Beans is known to be a host for *Helicoverpa*<sup>1</sup>. The rotation cotton / beans present a strong risk of increasing the population of *Helicoverpa*. The common rotation in Africa is usually cotton/maize or cotton/sorghum. Maize and sorghum support strong population of generalist insect predators that will contribute to lower the insect pressure on cotton. This PMP strongly advise to avoid the rotation cotton/beans considering the risk of increasing the pressure of *Helicoverpa*.

The property of beans, cowpeas and legumes in general, to host or attract bollworm can be deviated into a pest control strategy. Significant beneficial effects can be obtained when cultural methods, botanicals and bio control agents are combined<sup>2</sup>. Such approaches can be encapsulated in the “**push-pull strategy**” in which repellent products/plants are deployed to ‘push’ colonizing insects away from cotton and also to conserve natural enemies. At the same time, the pests are aggregated on a sacrificial or trap crop, so that a selective control agent could be used effectively and economically to reduce the pest population. For example, beans/cowpea can be used as a trap crop for *Helicoverpa* and introduced in association with cotton. Beans/cowpea with high population of pests can then be treated with chemicals or natural products (neem) to eliminate the bollworm from the field and protect cotton.

### 5.3.3 Disease

No disease have been reported in Malawi regarding cotton.

<sup>1</sup> Life Table Studies of the Cotton Bollworm, *Helicoverpa armigera* (Hübner) (Lepidoptera: Noctuidae), on Different Host Plants Restricted access. Zhudong Liu, Dianmo Li, Peiyu Gong, Kunjun Wu, 2004.

<sup>2</sup> Push-pull Strategy with Trap Crops, Neem and Nuclear Polyhedrosis Virus for Insecticide Resistance Management in *Helicoverpa armigera* (Hubner) in Cotton, P. Duraimurugan and A. Regupathy, 2005.

## 5.4 MAJOR PESTS AND DISEASES OF TROPICAL FRUITS

### 5.4.1 Banana

Banana has been growing naturally in Malawi for generations. Typically each household or village will have a handful of banana suckers to serve their daily needs. Local people have a deep-rooted understanding of how to cultivate the fruit from careful planting to picking at optimum ripeness.

The major diseases included Fusarium wilt, banana bunchy top virus and black sigatoka, while banana weevils and nematodes were the major pests. In most cases farmers in Malawi uproot or cut down their bananas, as they do not know the appropriate pest and disease control technologies.

Table 5-5 : Summary of pests of banana in Malawi

Pest Categories	Common name	Scientific name	Geographic distribution in Malawi Yes/No/not sure
Nematodes	Spiral nematodes	<i>Helicotylenchus</i> spp	Yes
	Burrowing nematodes	<i>Radppholus similis</i>	Yes
	Rootknot nematodes	<i>Meloidogyne</i> spp.	Yes
	Lesion nematode	<i>Pratylenchus</i> spp.	Yes
	Reniform nematode	<i>Rotylenchus</i> spp.	Yes
Arachnida	Reddish-back flat mite	<i>Brevipalpus phoenicis</i> / <i>Tetranychus amicus</i>	Yes
Hemiptera	Banana aphid	<i>Pentalonia nigronervosa</i>	Yes
	Red scale	<i>Aonidiella aurantii</i>	Yes
	Circular purple scale	<i>Chrysomphalus aonidum</i>	Yes
Coleoptera	Common fruit chafer	<i>Pacnoda sinuate flaviventris</i>	Not sure
	Banana weevil	<i>Cosmopolites sordidus</i>	Yes
Lepidoptera	Tomato semi-looper	<i>Chrysodeixis acuta</i>	Yes
Fungal and bacterial infections	Fusarium wilt	<i>Fusarium oxysporum</i> f.sp. <i>Cubense</i>	Yes
	Black sigatoka	<i>Mycosphaerella fijiensis</i>	Yes
	Yellow sigatoka	<i>Mycosphaerella musicola</i>	Yes
	Cigar-end rot	<i>Verticillium theobromae</i>	Yes
	Moko disease	<i>Ralstonia solanacearum</i> , race 2	Yes
Viruses	Banana streak disease	<i>Banana streak virus</i> (BSV)	Yes
	Banana bunchy top disease	<i>Banana bunchy top virus</i> (BBTV)	Yes

Source: Report of the workshop and field visits of the feasibility study on developing virus indexing capacity for banana planting materials in Malawi, 2013, Dr. Elize Jooste (ARC-PPRI, Pretoria, South Africa) & Ms Marianna Theyse (PhytoSolutions)

Management of Banana pests and diseases in Malawi include:

- Cultural control
  - Use of healthy plants for plantation

- Use of resistant varieties
- Disinfection of cutting tools
- Destruction of infected plants
- Chemical control
  - Apply fungicide (carbamate) and/or insecticide (Cypermethrin)
- Biological control
  - A large number of beneficial organisms (parasite, predators and pathogens) occur naturally in banana plantations. The spiders coccinellids lacewings spiders, coccinellids, lacewings , reduviids ants and reduviids, ants and parasitic flies and wasps are the most important beneficial insect groups active beneficial insect groups active in banana plantations.
  - Use of predators (*Plaesius javanus*, *Odontomachus spp.*) to control banana weevil.
  - Use of pathogen (*Beauveria*, *Metarrhizium*) to control banana weevil.

## 5.4.2 Mangoes

Mangoes just like any other agricultural crop, is susceptible to pest and disease attack which affect productivity. Some of the common pests and diseases in mangoes are outlined below along with their recommended management practices in Malawi.

### ANTHRACNOSE

- Caused by *Glomerella cingulata*.
- Causes discolouration of young leaves and premature ripening of fruits.
- Causes wilting and poor fruit set.
- Characterised by small, black sunken lesions on fruits.
- The lesions aggravate with wet weather, increasing in size, cracking the fruit and causing
- rotting.
- Tear staining may occur on fruit when spores are washed down from an infected twig or flower stalk.

### Control of Anthracnose:

- Spraying fungicides Captan, Dithane, Zineb and Maneb at 300g in 100 litres of water.
- Apply every three weeks after blossoming and later when the fruit has reached full
- development.
- Alternatively spray Benomyl (Benlate) 50WP at the rate of 15g in 10 litres of water.

### POWDERY MILDEW

- Caused by *Oidium mangifera* and attacks buds, flowers and young fruit.
- Leaves develop blotchy lesions and are malformed.
- Infected plant parts are covered in whitish powdery growth of the fungus hence the name.
- Cool weather aggravates the disease.
- Fruit set, size and quality are compromised.

Control of powdery mildew:

- Spraying Benomyl (Benlate) 50 WP at the rate of 15g in 10 litres of water every two weeks.
- Maintain proper pruning of the trees to reduce build-up of humidity within the canopy.

WEEDS

- Keep the basins around the trees weed free and should be mulched to conserve moisture and suppress weeds.
- All the area outside the basins (within) the orchard and surrounding areas should be slashed and the grass kept short.

MANGO STONE WEEVIL (*STERNOCHETUS MANGIFERA*)

- The larva enters the fruit during early stages of development.
- It leaves no external mark of entry with the fruit looking damage-free.
- Fruits fall prematurely from the tree and rot in transit, markets and storage.

Control of mango stone weevil:

- Collect and bury all pre-maturely falling fruits as soon as they fall and should not be mixed with other fruit.

MANGO FRUIT FLY (*CERATITIS CAPITATA*)

- Larvae bore into fruit making tunnels and bacteria take advantage and rot the fruit.
- Causes premature fruit fall.

Control of mango fruit fly:

- All fallen fruits should be collected and buried as soon as they have fallen.
- Chemical control by spraying Fenthion (Labaycid) 50EC at a rate of 1ml in 2 litres of water.
- Sprays should start when the fruits have just formed.
- Harvest the fruit when physiologically mature and while still on the tree.

General Management of mango orchards:

- Cultural control
  - Field sanitation- collection and destruction of all fallen fruits at weekly interval till harvest (This will destroy adults which is a source of infestation for the following year).
  - Rake the soil below the tree in October/ November and March to destroy weevils hiding under clods/ fallen leaves.
  - After harvest destroy all left-over seeds in the orchard, or in the processing industries.
- Chemical control
  - Spray main trunk, primary branches and junction of branches prior to flowering (November/ December) with chlorpyrifos 0.05%, to control beetles hiding in the bark.
  - Spray acephate 0.1125% at lime size followed by decamethrin 0.0028% after two to three weeks.
- Biological control



Parasitoids are unknown on stone weevil. The natural enemies recorded on *S. gravis* include a mite *Rhizoglyphus* sp. (Acarina: Tyroglyphidae) ants (*Camponatus* sp., *Monomorium* sp. and *Oecophylla smaragdina* Fab.) (Hymenoptera: Formicidae) and a fungus *Aspergillus* sp.. On *S. mangiferae* only a virus has been recorded. Therefore, scope for using biological control for weevil management with the existing information is limited. Recently, *Beauveria bassiana* (Balsamo) Vuillemin was to be pathogenic on mango stone weevil.

## 5.5 MAJOR PESTS AND DISEASES OF MAIZE / SORGHUM

Maize is grown throughout the Shire Valley under rainfed conditions. It is the main staple food crop. As such, farmers are encouraged to store enough maize for their family requirements until the next harvest and sell only surplus.

Maize pests are categorized into weeds and insects pests.

### 5.5.1 Weeds

The main weeds are:

- Witchweed (*Striga asiatica*) is becoming an increasingly serious problem;
- Wild finger millet (*Eleusine indica*), Kapinga (*Cynodon dactylon*) and wild oat (*Avena fatua*);
- *Nicandra Physaloides*, *Bidens pilosa* and *Amaranthus* sp.;
- Sedges such as *Cyperus rotundus* and *Cyperus esculentus*.

Control of these weeds is by done in the Shire Valley by frequent manual weeding and use of systemic herbicides such as glyphosate. Pre-emergence herbicides are also used like atrazine and metalochlor.

### 5.5.2 Insects

The main insects are:

- Armyworm (*Spodoptera exempta*) is a serious notifiable pest of cereals which is very destructive particularly to maize. Armyworm is an endemic pest and attack may be sudden;
- Maize stalk borer (*Busseola fusca*, *Chilopartellus*);
- Larger Grain Borer (*Prostephanus truncates*) is a grain storage insect pest which causes heavy losses in maize;
- Maize weevil (*Sitophilus zeamais*) is responsible of grain losses during storage.

There is no specific control practises for armyworm and stalk borer. In case of massive infestation spraying of insecticide Cypermethrin is done in Malawi.

The control of larger grain borer is done by the use of storage insecticide, Pirimiphos methyl, Cypermethrin and Deltamethrin. The use of these storage insecticides is systematic.

## 5.6 MAJOR PESTS AND DISEASES OF RICE

Rice is another important food and cash crop. Some rice is grown in upland areas and some rice is grown under irrigation. Irrigated rice farming faces a number of pests and disease problems. However, most of them do not need pesticide application, especially in rainfed areas. The major pests and disease of rice and recommended management practises in Malawi are presented in the table below.

**Table 5-6 : Major pests and disease of rice and recommended management practises**

Pests		Recommended management practices
Insects	Stem borers ( <i>Chilo partellus</i> , <i>C. orichalcociliellus</i> , <i>Maliarpha separatella</i> , <i>Sesamia calamistis</i> )	- Plant recommended early maturing varieties - Destruction of eggs in the seedbeds - Early planting - Use recommended plant spacing - Minimise simultaneous planting as this provides food continuously for the pest
	Stalk-eyed fly ( <i>Diopsis</i> spp)	- Destruction of stubble after harvest
	African rice gall midge ( <i>Orseolia oryzivora</i> )	- Clean weeding
	Small rice grasshoppers ( <i>Oxya</i> spp.)	- Plough after harvest to expose the eggs to natural enemies
	African armyworm ( <i>Spodoptera exempta</i> )	- Resistance varieties - Stalk management in dry season
	Flea beetles ( <i>Chaetocnema varicornis</i> )	- Suspected to be the key vector of rice yellow mottle virus (RYMV). No known control measures.
	Rice hispa ( <i>Dicladisa</i> sp)	- Found mostly in irrigated fields. Avoid stagnant water in the fields
Weeds	Cyperus rotandus, striga All types	- Early clean weeding - Use recommended herbicides if necessary
Diseases	Rice yellow mottle virus (RYMV)	- Field sanitation including burning of crop residues and removal of volunteer plants - Use of resistant varieties
	Rice blast ( <i>Pyricularia oryzae</i> )	- Destruction of crop residues - Clean seeds
	Brown leaf spot ( <i>Helminthosporium</i> spp)	- Avoid use of excessive nitrogen fertilizers - Use resistance varieties
	Sheath rot ( <i>Acrocyndrium oryzae</i> )	- Appropriate crop rotation - Timely planting - Burying crop debris
Vermins	Birds Rats	- Scaring - Bush clearing - Early harvesting - Spraying against Red-billed Quelea ( <i>Quelea quelea</i> )

Source : Guide to Agricultural Production and natural Resources Management in Malawi, Ministry of Agriculture and Food Security, 2003.

## 5.7 MAJOR PESTS AND DISEASES OF BEANS

Common beans or *Phaseolus* may be regarded as one of the principal sources of protein as well as income to most farmers in Shire Valley districts. Beans are grown throughout the country with major production under rainfed system and some under irrigated system. Consequently, the pest pressure and type vary due to agro-ecological and management differences. Small-scale farmers grow beans mainly as intercrop with maize, while large-scale farmers grow them as mono crop. In contrast to large-scale farmers, who apply a wide spectrum of chemicals, small scale farmers in Malawi mainly apply cultural practices to control pests and disease in beans.

The most common diseases in beans are angular leaf spot disease, anthracnose, bean rust, and root rots. These are disease transmitted by fungi. One of the common causes of severe damage is the intensive cultivation of beans without sufficient rotation, the cultivation of resistant varieties and seed dressing are potential integrated pest management control measures, but farmers have also to be trained in the proper diagnosis of the diseases.

The common pests in beans are stem maggots, aphids, bruchids and foliage beetles. Maggots of the bean fly and foliate beetles cause damage to the beans while in the field. Bruchids are storage insects that may cause severe loss of crop. Storage hygiene, improved storage structures and the application of ash, vegetable oil and botanicals, such as Neem and Tephrosia, are among the potential integrated pest management control measures of bean bruchids. Maggots and foliage beetles may be controlled by seed dressing or spraying with botanicals, or by cultural practices, including rotation, post-harvest tillage and earthing-up mulching.

## 5.8 MAJOR PESTS AND DISEASES OF HORTICULTURAL CROPS

Shire Valley Region is well known for growing several horticultural crops such as tomatoes, cabbages, carrots, beans and sweet pepper. Tomatoes and cabbages are the main horticultural crops grown.

Cabbages are mainly grown for income generation and farmers apply available chemicals mainly to control insect pests. The most common disease affecting cabbage is black rot which is caused by bacteria *Xanthomonas campestris* and spreads through infected crop debris and seed. Wet warm weather conditions encourage the development of bacteria populations. Cultural control measures, such as deep ploughing, crop rotation and field sanitation considerably reduce the damage by black rot. Other potential IPM control techniques include seed dressing with Bacillus bacteria, seed treatment with hot water or antibiotics, and resistant varieties.

Diamond black moth and cabbage head worm are the most devastating insect pests affecting cabbages. Dry and hot weather conditions and the presence of host plants encourage the insect populations to develop. Farmers apply insecticides (Cypermethrin) or cow dung and urine to control the pests. Application of Neem oil has proven to be effective, while the effect of natural enemies and other botanicals, such as Diadegma, Tephrosia and Annona seeds should be verified. An alternative control agent is Bt-Bacillus thuringiensis.

Ash aphids (*Brevocoryne brassicae*) are also major pest of cabbage in most parts of Malawi. The same control measures as above for the Diamond black moth can be applied successfully to control this insect.

Figure 5 : Major insect pests and damage caused to vegetables in Malawi

### Major insect pests and damage caused to vegetables in Malawi



Legume pod borer



Root-knot nematode



Tomato fruit worm



Cabbage aphid infestation



Cutworms

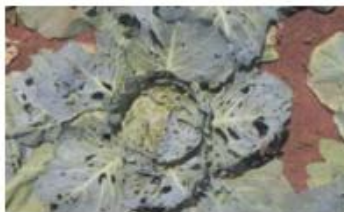

Cabbage damaged by DBM



DBM adult, larva & cocoon



Effect of DBM on tomato



Onion thrips



Termite damage on pigeon pea

Source: Vegetable Research and Development in Malawi, 2003, M.L. Chadha, M.O. Oluoch, A.R. Saka, A.P. Mtukuso, and A.T. Daudi.

## 5.9 SYNTHESIS OF PESTICIDES USED IN SHIRE VALLEY

### 5.9.1 Toxicity for human health and environment of the pesticides used

The table below shows the different molecules used in the Shire Valley and their toxicity according to “The WHO Recommended Classification of Pesticides by Hazard and Guidelines to Classification 2009”. This classification distinguishes between the more and the less hazardous forms of each pesticide in that it is based on the toxicity of the technical compound and on its formulations.

In the Shire Valley, Illovo manages pesticides by training its workers on pesticides use and disposal. Illovo workers wear protective clothes when spraying pesticides. Illovo also has an incinerator to destroy empty containers. Workers in contact with pesticides have regular blood tests to avoid any contamination. The work done by this company for the safety of its workers is an example to follow. However, this level of safety and control measures for the workers is not attained by outgrowers and rainfed farmers. Most of their pesticides containers are washed and given to the community to be reused.

This PMP has also used the Globally Harmonised System of Classification and Labelling of Chemicals (GHS). The goal of the GHS is to identify the intrinsic hazards found in substances and mixtures and to convey hazard information about these hazards.

**Figure 5-6 : WHO class for pesticides**

WHO Class		LD <sub>50</sub> for the rat (mg/kg body weight)	
		Oral	Dermal
Ia	Extremely hazardous	< 5	< 50
Ib	Highly hazardous	5–50	50–200
II	Moderately hazardous	50–2000	200–2000
III	Slightly hazardous	Over 2000	Over 2000
U	Unlikely to present acute hazard	5000 or higher	

Source: The WHO Recommended Classification of Pesticides by Hazard and Guidelines to Classification 2009

**Table 5-7 : Main pesticides used in the Shire Valley and their toxicity**

Type of crops	Name of Molecule used	Classification according to WHO 2010	GHS
Sugarcane	Abamectin	Extremely hazardous	H300: Fatal if swallowed H332: Harmful if inhaled H400: Very toxic to aquatic life H410: Very toxic to aquatic life with long lasting effects
Sugarcane	Chlorpyrifos	Moderately hazardous	H301: Toxic if swallowed. H400: Very toxic to aquatic life. H410: Very toxic to aquatic life with long lasting effects.
Sugarcane	Fipronil	Moderately hazardous	H301: Toxic if swallowed. H311: Toxic in contact with skin. H331: Toxic if inhaled. H400: Very toxic to aquatic life. H410: Very toxic to aquatic life with long lasting effects.

Type of crops	Name of Molecule used	Classification according to WHO 2010	GHS
Sugarcane / Cotton / Maize / horticulture	Cypermethrin	Moderately hazardous	H301: Toxic if swallowed. H332: Harmful if inhaled. H335: May cause respiratory irritation. H400: Very toxic to aquatic life. H410: Very toxic to aquatic life with long lasting effects.
Sugarcane	Imidachloprid	Moderately hazardous	H301: Toxic if swallowed.
Sugarcane	Triadimefon	Moderately hazardous	H302: Harmful if swallowed. H317: May cause an allergic skin reaction. H411: Toxic to aquatic life with long lasting effects.
Sugarcane	Pendimethalin	Moderately hazardous	H317: May cause an allergic skin reaction H400: Very toxic to aquatic life H410: Very toxic to aquatic life with long lasting effects
Sugarcane / Maize / Cotton	Glyphosate	Slightly hazardous	H315: causes skin irritation H320: causes eye irritation
Sugarcane	MCPA	Moderately hazardous	H302: Harmful if swallowed. H315: Causes skin irritation. H319: Causes serious eye irritation. H332: Harmful if inhaled.
Sugarcane	Triclopyr	Moderately hazardous	H315: Causes skin irritation. H317: May cause an allergic skin reaction. H320: Causes eye irritation. H335: May cause respiratory irritation. H410: Very toxic to aquatic life with long lasting effects.
Sugarcane	fluazifop-P-butyl	Slightly hazardous	H361d: Suspected of damaging the unborn child. H315: Causes skin irritation. H317: May cause an allergic skin reaction. H410: Very toxic to aquatic life with long lasting effects.
Sugarcane	MSMA	Moderately hazardous	H303: May be harmful if swallowed. H332: Harmful if inhaled. H412: Harmful to aquatic life with long lasting effects.
Sugarcane	ametryn	Moderately hazardous	H351: Suspected of causing cancer
Sugarcane	Butachlor	Slightly hazardous	H302: Harmful if swallowed H400: Very toxic to aquatic life
Sugarcane	Metribuzin + Chlorimuron	Moderately hazardous	H302: Harmful if swallowed H410: Very toxic to aquatic life with long lasting effects.
Sugarcane	hexazinone	Moderately hazardous	H302: Harmful if swallowed H319: Causes serious eye irritation H400: Very toxic to aquatic life H410: Very toxic to aquatic life with long lasting effects
Cotton	Acetochlor	Slightly hazardous	H315: Causes skin irritation H317: May cause an allergic skin reaction H302: Harmful if swallowed H335: May cause respiratory irritation H410: Very toxic to aquatic life with long lasting effects
Cotton	Carbaryl	Moderately hazardous	H302: Harmful if swallowed H302: Harmful if swallowed

Type of crops	Name of Molecule used	Classification according to WHO 2010	GHS
			H370: Causes damage to organs
Cotton	Profenofos	Moderately hazardous	H302: Harmful if swallowed H316: Causes mild skin irritation H317: May cause an allergic skin reaction H320: Causes eye irritation H332: Harmful if inhaled H371: May cause damage to organs H400: Very toxic to aquatic life H410: Very toxic to aquatic life with long lasting effects
Cotton	Triazophos	Highly hazardous	H301: Toxic if swallowed H312: Harmful in contact with skin H331: Toxic if inhaled H400: Very toxic to aquatic life H410: Very toxic to aquatic life with long lasting effects
Cotton	Dimethoate	Moderately hazardous	H301: Toxic if swallowed H311: Toxic in contact with skin H320: Causes eye irritation H370: Causes damage to organs H373: Causes damage to organs through prolonged or repeated exposure H401: Toxic to aquatic life H411: Toxic to aquatic life with long lasting effects
Cotton	Lambda-cyhalothrin	Moderately hazardous	H301: Toxic if swallowed H311: Toxic in contact with skin H320: Causes eye irritation H370: Causes damage to organs H372: Causes damage to organs through prolonged or repeated exposure H400: Very toxic to aquatic life H410: Very toxic to aquatic life with long lasting effects
Cotton	Cyfluthrin	Highly hazardous	H302: Harmful if swallowed H319: Causes serious eye irritation H330: Fatal if inhaled H361: Suspected of damaging fertility or the unborn child H370: Causes damage to organs H372: Causes damage to organs through prolonged or repeated exposure H400: Very toxic to aquatic life H410: Very toxic to aquatic life with long lasting effects
Cotton	Fenvalerate	Moderately hazardous	H301: Toxic if swallowed H313: May be harmful in contact with skin H316: Causes mild skin irritation H317: May cause an allergic skin reaction H320: Causes eye irritation H330: Fatal if inhaled H335: May cause respiratory irritation (respiratory tract irritation) H370: Causes damage to organs (nervous system) H373: May cause damage to organs through prolonged or repeated exposure (nervous system)

Type of crops	Name of Molecule used	Classification according to WHO 2010	GHS
			H400: Very toxic to aquatic life H410: Very toxic to aquatic life with long lasting effects
Cotton	Thiodicarb	Moderately hazardous	H301: Toxic if swallowed H320: Causes eye irritation H361: Suspected of damaging fertility or the unborn child H370: Causes damage to organs H373: Causes damage to organs through prolonged or repeated exposure H400: Very toxic to aquatic life H410: Very toxic to aquatic life with long lasting effects
Maize	Atrazine	Slightly hazardous	H317: May cause an allergic skin reaction H373: May cause damage to organs through prolonged or repeated exposure H400: Very toxic to aquatic life H410: Very toxic to aquatic life with long lasting effects
Maize	Metalochlor	Slightly hazardous	H227: Combustible liquid H304: May be fatal if swallowed and enters airways
Maize	Pirimiphos methyl	Moderately hazardous	H302: Harmful if swallowed H319: Causes serious eye irritation H361: Suspected of damaging fertility or the unborn H372: Causes damage to organs through prolonged or repeated exposure
Maize / Cotton	Deltamethrin	Moderately hazardous	H315: Causes skin irritation H319: Causes serious eye irritation
Rice	2,4-D	Moderately hazardous	H302: Harmful if swallowed. H318: Causes serious eye damage. H317: May cause an allergic skin reaction. H335: May cause respiratory irritation. H412: Harmful to aquatic life with long lasting effects

### 5.9.2 Environmental and safety concerns with pesticides

Agrochemicals in use in the Shire Valley have the potential to cause undesirable effects on the environment, and on the health of operators and communities. Negative environmental impacts include pollution of water, soil and air and consequent impacts on organisms in the water, soil and air. This can occur from drift after spraying or direct effects in the soil. Runoff of topsoil may carry agrochemicals into streams. Agrochemicals may become bound to soil particles and held in the soil or leached through soil profiles, depending on their characteristics, such as solubility and adsorption. Chemicals may also differ in their persistence due to differing half-lives (degradation rates). Weather conditions can have an influence on the pollution potential of chemicals. Wind and low relative humidity increase drift and heavy rains cause leaching in sandy soils. Chemicals differ in their inherent toxicity to organisms in the environment and to humans but the degree of impact is also affected by exposure time, the absorption pathway and the formulation of the pesticide.



## 6. INTEGRATED PEST CONTROL AND MANAGEMENT OPTIONS

### 6.1 IMPORTANCE OF IPM

Integrated Pest Management (IPM) refers to a mix of farmer-driven, ecologically based pest control practices that seeks to reduce reliance on synthetic chemical pesticides. It involves (a) managing pests (keeping them below economically damaging levels) rather than seeking to eradicate them; (b) relying, to the extent possible, on non-chemical measures to keep pest populations low; and (c) selecting and applying pesticides, when they have to be used, in a way that minimises adverse effects on beneficial organisms, humans, and the environment.

As noted in den Belder & Elings (2007)<sup>3</sup>, IPM techniques can be separated into two major groups: (i) relatively straightforward replacements for chemicals, and (ii) supporting measures. Chemical replacements include:

- **Biological control:** the introduction of insects, mites, micro-organisms that prey on or parasitise harmful species.
- **Biopesticides:** these have a pathogenic micro-organism as the active ingredient, for example a bacterium or a virus (for example, Bt).
- **Botanicals:** botanical pesticides contain plant extracts that have biocidal properties (for example, neem).
- **Semichemicals:** chemicals (especially pheromones) are used to stimulate particular behaviours or interactions between individual insects so as to control pests.

Choosing appropriate measures is not straightforward and requires significant understanding of the interactions between environment, crop, pest and predator. The scientific basis for farmer decision making in biological control depends on detailed knowledge of the life histories of pests and their natural enemies, crop ecology, and interactions within the agro-ecosystem. Farmer participation and learning are essential.

Supporting measures include traditional methods of pest control as used in subsistence farming systems: cultural control (e.g., intercropping), habitat manipulation (e.g., creating diversity), mechanical and physical control, natural biological systems, and host plant resistance.

### 6.2 RISKS

Increased use of pesticides without associated major improvements in knowledge, attitude and practice in chemical application, equipment, storage and container disposal will:

- Increase existing hazards and risks, both of occupational exposure (farmers, sprayers) and local residents;
- Increase pesticides residues in food crops, milk and meat with potential impacts on human health.
  - In addition, drift and runoff will rapidly enter the aquatic environment which is closely linked to Shire river, with potentially significant consequences for aquatic wildlife and the associated food chain (e.g. fish, reptiles, birds).
  - Impacts on bees and other pollinators will increase further, since some of the chemicals now in use or recommended (e.g. chlorpyrifos) are highly toxic to honeybees.

<sup>3</sup> Integrated Pest Management in Ethiopian Horticulture, Belder & Elings (2007)

## 6.3 POTENTIAL IMPACTS AND CHALLENGES ASSOCIATED WITH SVIP IMPLEMENTATION

This section assesses the likely potential impacts of the extension of the irrigated area for the plantation of sugarcane, maize, rice, beans and horticultural crops.

### IMPACT OF PESTICIDES ON WATER BODIES

The use of agro-chemicals on irrigated farms could impact on the raw water sources. The excessive use of agro-chemicals such as herbicides/insecticides can contaminate the water bodies through run off especially during the rainy season and/or water logging.

The over concentration of toxic chemicals in water is a major health risk for the local population and aquatic/fish life. This is because some households use water from canals/drains for domestic purposes. Children also usually swim in some canals/drains. Another source of water pollution may be from the return flow of irrigation water heavily with polluted with inorganic salts into the Shire River. Draining excess water contaminated with agro-chemicals from the irrigation fields into the Shire river will be a source of water pollution.

### IMPACT OF PESTICIDES ON AQUATIC FAUNA

Pollution from agrochemicals may also affect aquatic life in water bodies. Some pesticides used are very toxic to aquatic life. Excess water drained outside irrigation scheme into the Shire river will be contaminated with these pesticides. This can cause major disturbance of the aquatic life.

### IMPROPER PESTICIDE USE AND DISPOSAL OF PESTICIDE CONTAINERS

This is caused by poor knowledge, inadequate equipment and storage and the use of an excessive dosage.

Illovo Estate trains its workers on pesticides use and disposal. Illovo has an incinerator to destroy empty containers. Workers in contact with pesticides have regular blood tests to avoid any contamination. The work done by this company for the safety of its workers is an example to follow.

This level of safety and control measures for the workers is not attained by the outgrowers. The extension of irrigated area will lead to an increase of the total quantity of pesticides used and also to an increase of the number of workers in contact with pesticides. If a specific attention is not made on this issue, the number of contamination will increase in the area leading to a major public health problem.

The production of horticultural crops will increase under SVIP and so will the quantity of pesticides used and the number of farmers in contact with pesticides.

Proper storage to prevent pests from ravaging the grains is essential. Improper use of pesticides during storage is a concern as pesticide residues above the Maximum Residue Level (MRL) are more likely to occur with stored grains.

Pesticide containers have been found to be reused at homes. Improper washing or cleaning could lead to harmful consequences where containers are reused as food or drink containers. The population groups at risk include women, children, elderly and rural farmers who are mostly illiterate and principal users of empty containers without proper treatment. An increase in pesticide containers in the project area is expected during the implementation stage and proper collecting system and disposal is required to minimize reuse of containers for domestic activities.

## CROPPING PATTERN AND CROP CALENDAR

As this PMP has highlighted (see 5.3.2), beans are hosts for *Helicoverpa armigera*. The proposed crop rotation cotton / beans will certainly increase the population of this pest with negative consequences on the cotton the season after. This PMP recommends that a rotation cotton/cereals like cotton/maize or cotton/sorghum is adopted to cut the cycle of cotton insects.

In the proposed cropping pattern maize and sorghum are planned to be grown during the cold and dry season (April to September). Rainfed maize is conventionally grown during hot and wet season (November to March). So during the cold and dry season, the irrigation scheme will be the only area covered with maize in the Shire valley. It can be expected that insect pests will find refuge in the maize fields. Control of insects in the irrigated maize fields will be more costly.

Further, since the crops in the SVIP will be grown even in the dry season, when there are less alternative hosts elsewhere, high pest pressure on irrigated crops must be anticipated in dry season because the irrigated crops will be the focal point for the pests.

## PRODUCTION LOSSES AND FOOD SECURITY CONCERNS FROM ARMYWORM AND OTHER CROP PESTS AND DISEASE OUTBREAKS

Armyworms are occasional pests but when they occur, the devastation is alarming and disastrous. The project will put large area of land under irrigated cereal and pulse cultivation and this can easily be devoured within few days during armyworm outbreaks. Food security concerns will arise because an outbreak could wipe-off most, if not all cereal/pulses farms, within few days. Cereals and pulses are key staple foods of Malawians. Adequate armyworm surveillance is required to contain and eliminate any threat.

Horticultural production has always been a hot spot for both pests and disease losses and the sometimes excessive use of agrochemicals. Any form of production losses will impact negatively on crop prices in the local market.

## CONCLUSION ON POTENTIAL IMPACTS AND CHALLENGES ASSOCIATED WITH SVIP IMPLEMENTATION

Maize/Sorghum and beans are cultivated everywhere under rainfed conditions in the Shire Valley. All pests and diseases of those crops described in the previous chapters are already present and well-known by the farmers. The conversion of rainfed area into irrigated area will not change the pressure of pests and diseases on crops. On the contrary, irrigation will allow to grow more healthiest crops (no water stress) and so, more resistant crops to pests and diseases.

The main challenge with SVIP implementation is the pesticide use and the disposal of containers. If this issue is not taken into account seriously, it will lead to human and environmental contaminations. Illovo could play a central role in this challenge. Illovo is used to train workers on pesticides use and disposal. SVIP could rely on Illovo to assure the training of the workers in the extensions and also help to implement a procedure for containers elimination (collect and incineration). A specific contract between Illovo and SVIP could be signed for this purpose.

## 6.4 PROPOSED MANAGEMENT OPTIONS

### 6.4.1 Pest Problems and Control Practices

#### SUSTAINABLE CONTROL OF PESTS IN SUGARCANE PLANTATION

Control of the pests has mostly relied on highly hazardous pesticides. Of all the actions associated with growing sugarcane, the greatest risk to the well-being of farmers, farm workers and rural communities, comes from the use of pesticides. They also present a risk to non-target organisms and to the environment.

Currently, there are a number of management practices that can be used to control sugarcane pests and which present little or no risk to the well-being of people or the environment.

These include:

- **Use of biological control agents** – predators and parasitoids. Also habitat management using insect repellent plants.
- **Use of benign chemicals and biopesticides** – e.g. *tebufenozide*, neem based products and formulations of *Metarhizium spp.*
- **Adoption of various agronomic practices** – e.g. planting pest free seedcane; using resistant and tolerant cultivars; management of planting or harvesting dates to the detriment of certain pest species; adopting green cane harvesting with a trash blanket and replanting using minimum tillage; use of organic amendments in the planting furrow to enhance early plant growth and reduce damage caused by nematodes; avoiding moisture stress through irrigation; intercropping and rotation cropping with cash crops (including rotation with soybean that favours beneficial nematodes); flooding fields for short periods; avoidance of high levels of N and low levels of Si.
- **Capture of pests** – hand picking and the use of trap crops, light traps and pheromone traps.

To reduce the risk of poisoning and environmental contamination, and until safer control options are available, greater emphasis has to be placed on (a) training farm workers, (b) the provision of appropriate safety clothing and (c) improved application technology.

Highly hazardous pesticides should be withdrawn from countries where safe handling cannot be guaranteed within margins of acceptable risk to the user (FAO 2010).

#### SUSTAINABLE CONTROL OF WEEDS IN SUGARCANE PLANTATION

Suggested actions for optimizing performance in respect of effective weed control, minimizing cost, minimizing negative social impacts and minimizing negative environmental impacts:

- Good husbandry practices to promote fast and healthy cane growth – correct variety choice, row spacing, seedcane quality and quantity, timing of harvest and planting with respect to soil type and weather conditions.
- Knowledge of the weed spectrum in all fields.
- Selection of a suitable weed control program (based on weed spectrum, expected time to canopy, soil type, available herbicides for specific weeds, season, moisture regime, labor availability).
- Timing of herbicide application with respect to weed growth stage, soil tillth and moisture conditions (most pre-emergence herbicides require 10-14 mm of rain within two weeks of application).

- Training of spray equipment operators in application and safety.
- Sufficient spray capacity so that the operation can follow closely behind planting or harvesting (e.g. one knapsack/15 ha).
- Servicing and calibration of spray equipment to ensure accurate application rates and coverage (including use of low pressures and correct nozzle selection for coverage and low drift. All knapsacks should be fitted with pressure regulators and operators should be trained on their maintenance. Promoting the use of shields where appropriate to prevent drift.
- Preference for directed inter-row application and minimizing contact with cane.
- Selection of appropriate chemicals for stage of application (soil applied or foliar applied); weed species; minimizing possibility of leaching to groundwater and from contaminating surface water; minimizing potential for poisoning of operators and toxic effects on micro and macro fauna; minimizing residual chemicals.
- Abiding by label instructions and laws for safety, efficacy, disposal and washing with all chemical applications.
- Minimizing chemical use where possible.

Practice of choice:

### **Harvest Cane without Burning and Use the Trash Blanket For Weed Control**

This is the ideal solution for providing effective weed control, minimizing weed control costs, preventing herbicide damage, and added benefits of enhancing soil carbon, preventing soil erosion and conserving moisture. It is agreed that the downside of trash blankets such as increased pests, poor regrowth in wet and cold conditions, higher cost and usually poorer quality of manual harvesting, increased fire risk, and problems with some weeds adapted to trash blankets, are not insurmountable and, with some consideration and adjustments to systems, can be successfully overcome.

### **SUSTAINABLE CONTROL OF DISEASES IN SUGARCANE PLANTATION**

Aspects of control that must be incorporated into every sugarcane enterprise include the following:

- Variety resistance.
- Seedcane health, achieved through a planned, well managed system of seedcane production.
- Effective destruction of the old crop before replanting. This is particularly important if the previous crop in the field to be planted was infected by a systemic disease.
- Monitoring the incidence of diseases to provide timely warning of any developing disease problem. Survey data can promptly enhanced attention to basic control measures or signal a need to change from a susceptible to a more resistant variety.

**Varietal resistance is the most cost-effective and most suitable method of controlling almost all sugarcane diseases in the long term.**

### **MANAGEMENT OF POST HARVEST PESTS OF CEREAL CROPS**

Losses due to damage caused by the larger grain borer, weevils, rats/rodents, aflatoxins, and grain moths can be minimized through the following IPM strategies:

- Selection of tolerant varieties
- Timely harvest
- Dehusking and shelling
- Proper drying

- Sorting and cleaning of the produce before storage
- Cleaning & repair of storage facilities
- Use rodent guards in areas with rat problems
- Use improved granaries
- Use appropriate natural grain protectants where applicable
- Use recommended insecticides at recommended dosage
- Store grain in air tight containers. Where airtight containers are used store these in a shady place, preferably in-doors on raised platform to allow air circulations and prevent attack by mould.
- Carry out regular inspection of the store and produce. Timely detection of any damage to the grain and/or storage structure is essential to minimise potential loss or damage

Biological control of the LGB using *Teretriosoma nigrescens* (Tn) to minimise infestation from wild sources will be beneficial once appropriate strains of the Tn are identified and validated. This is a task of the government because the agents have to be reared and released in strategic sites.

#### SUSTAINABLE CONTROL OF PEST FOR OTHER CROPS

As highlighted in sections 4.3 to 4.8, several integrated pest control methods can be applied to the following crops: Cotton, Tropical fruits, Maize/Sorghum, Beans. This include the use of best management practices, the use of biological control (beneficial organisms, use of natural predators and pathogen, etc.

#### PESTICIDE APPLICATIONS -CEREALS, PULSES AND VEGETABLES - IN LINE WITH IPM APPROACHES

1. A decision to use chemical pesticides should be taken only as the very last resort and should also be based on conclusions reached from an agro-ecosystem analyses (AESA).
2. All pesticides should be EPA<sup>4</sup> approved and Ministry of Agriculture recommended.
3. If it is absolutely necessary to spray crops with pesticides, use selective rather than broad-spectrum pesticides.
4. All herbicides should be applied using knapsack sprayers.
5. All the insecticides for storage pests of cereals/pulses are in dust form and therefore used as supplied without mixing with anything else.
6. The list of pesticides can change as new products are recommended and/or some of the chemicals are withdrawn. Therefore always consult the retailer/stock list, the nearest Ministry of Agriculture extension worker if in doubt and/read the label.

#### PESTICIDE USE AND DISPOSAL OF PESTICIDE CONTAINERS

Store pesticides in their original packaging, in a dedicated, dry, cool and well aerated location that can be locked and properly identified with signs, with access limited to authorized people. No human or animal food may be stored in this location. The store room should also be designed with spill containment measures and sited in consideration of potential for contamination of soil and water resources.

---

<sup>4</sup> Environmental Protection Agency

Mixing and transfer of pesticides should be undertaken by trained personnel in ventilated and well-lit areas, using containers designed and dedicated for this purpose.

Containers should not be used for any other purpose (e.g. drinking water). Contaminated containers should be handled as hazardous waste, and should be treated accordingly. Disposal of containers contaminated with pesticides should be done in a manner consistent with FAO guidelines and with manufacturer's directions.

Purchase and store no more pesticide than needed and rotate stock using a 'first-in, first-out' principle so that pesticides do not become obsolete. Additionally, the use of obsolete pesticides should be avoided under any circumstances. A management plan that includes measures for the containment, storage and ultimate destruction of all obsolete stocks should be prepared in accordance to guidelines by FAO and consistent with country commitments under the Stockholm, Rotterdam and Basel Conventions.

### 6.4.2 Recommended list of pesticides

The table below present a list of recommended selective pesticides. Those pesticides are to be use if the others sustainable solutions cannot solve the problem: use of biological control agents, use of biopesticides, adoption of adapted agronomic practises, capture of pests, ...

**Table 6-1 : Recommended list of pesticides**

Type of crops	Name of Molecule used	Type of pesticide
Sugarcane	Chlorpyrifos	Insecticide
Sugarcane	Fipronil	Insecticide
Sugarcane	Imidachloprid	Insecticide
Sugarcane	Triadimefon	Fungicide
Sugarcane	Pendimethalin	Herbicide
Sugarcane	Métolachlor	Herbicide
Sugarcane	Metribuzin	Herbicide
Sugarcane	Isoxaflutol	Herbicide
Sugarcane	MCPA	Herbicide
Sugarcane	Triclopyr	Herbicide
Sugarcane	fluazifop-P-butyl	Herbicide
Sugarcane	MSMA	Herbicide
Sugarcane	ametryn	Herbicide
Sugarcane	Butachlor	Herbicide
Sugarcane	Metribuzin + Chlorimuron	Herbicide
Sugarcane	hexazinone	Herbicide
Sugarcane / Maize / Cotton	Glyphosate	Herbicide
Sugarcane / Cotton / Maize / horticulture	Cypermethrin	Insecticide
Cotton	Acetochlor	Herbicide
Cotton	Carbaryl	Insecticide
Cotton	Profenofos	Insecticide
Cotton	Dimethoate	Insecticide
Cotton	Lambda-cyhalothrin	Insecticide
Cotton	Fenvalerate	Insecticide
Cotton	Thiodicarb	Insecticide

Type of crops	Name of Molecule used	Type of pesticide
Maize	Atrazine	Herbicide
Maize	Metalachlor	Herbicide
Maize	Pirimiphos methyl	Insecticide
Maize / Cotton	Deltamethrin	Insecticide
Rice	2,4-D	Herbicide

### 6.4.3 Safety Management Systems

Good practices for safety management in agricultural production are likely to revolve around established procedures for workplace safety management and common sense. There are a number of situations in crop production where dangers of injury or health impairment exist. These include both physical hazards and chemical hazards. Options for reducing injuries or health impairment include (1) training of personnel in the safe use of equipment, (2) increased awareness of dangerous situations, (3) assessment of the risks involved in each operation, (4) use of protective clothing, and (5) attention to establishing procedures which limit the opportunity for injuries or exposure to harmful chemicals.

#### PRINCIPLES OF SAFETY MANAGEMENT

A number of principles for safety management are found in the literature, and a range of such principles includes:

- Safety audit or risk assessment
- Accident investigation and reporting
- Safety performance monitoring
- Safety education and training.

Others:

- Education
- Job site maintenance
- Safety equipment
- Communication.

SUGGESTED STEPS IN ESTABLISHING A SAFETY MANAGEMENT SYSTEM ARE ILLUSTRATED BELOW.

#### (A) Follow these steps:

1. Understand legal obligations
2. Educate staff on the need for safety and a safety management system.
3. With staff involvement, identify the hazards and evaluate the risks (risk assessment).
4. With staff involvement and following any manufacturers specifications identify work place safety equipment needs such as guards for moving parts, protective clothing for operators and signage for communication of dangers.
5. With staff involvement formulate safe work procedures for all tasks.
6. Train all staff in safe work procedures relevant for their work.
7. Establish safety committees and elect or select safety representatives.



8. Establish incidents and accident reporting systems, as well as a regular monitoring and evaluation program.
9. Ensure communication by all staff and management is in place to address any safety issues.

**(B)Take up a recognized Safety Management System or management system that incorporates health and safety (e.g. bsigroup 18001, ISO 9000) or become certified according to a recognized standard (e.g. Sustainable Agriculture Network standard)**

#### SUMMARY OF GOOD PRACTICES FOR ENVIRONMENTAL AND HUMAN SAFETY

The IFC (2007b)<sup>5</sup> lists a number of steps that can be taken to reduce the risk of poisoning or contamination of the environment when handling, diluting, applying and storing pesticides:

*“Train personnel in the correct way to handle and apply pesticides. This is **THE** most important single step to take to prevent poisoning of farmworkers.*

*Avoid the use of pesticides that fall under the World Health Organization Recommended Classification of Pesticides by Hazard Classes 1a and 1b and Hazard Class II.*

*Use only pesticides that are manufactured under license and registered and approved by the appropriate authority and in accordance with the Food and Agriculture Organization’s (FAO’s) International Code of Conduct on the Distribution and Use of Pesticides.*

*Use only pesticides that are labelled in accordance with international standards and norms, such as the FAO’s Revised Guidelines for Good Labelling Practice for Pesticides.*

*Select application technologies and practices designed to reduce unintentional drift or runoff as indicated in an IPM program, and under controlled conditions.*

*Maintain and calibrate pesticide application equipment in accordance with manufacturer’s recommendations.*

*Establish untreated buffer zones or strips along water sources, rivers, streams, ponds, lakes, and ditches to help protect water resources.*

*Avoid use of pesticides that have been linked to localized environmental problems and threats.*

*Store pesticides in their original packaging, in a dedicated, dry, cool, and well aerated location that can be locked and properly identified with signs, with access limited to authorized people. No human or animal food may be stored in this location. The store room should also be designed with spill containment measures and sited in consideration of potential for contamination of soil and water resources.*

*Mixing and transfer of pesticides should be undertaken by trained personnel in ventilated and well-lit areas, using containers designed and dedicated for this purpose.*

*Containers should not be used for any other purpose (e.g. drinking water). Contaminated containers should be handled as hazardous waste, and should be treated accordingly. Disposal of containers contaminated with pesticides should be done in a manner consistent with FAO guidelines and with manufacturer’s directions.*

---

<sup>5</sup> International Finance Corporation, World Bank Group, Environmental, Health, and Safety (EHS) Guidelines, Avril 2007.

*Purchase and store no more pesticide than needed and rotate stock using a 'first-in, first-out' principle so that pesticides do not become obsolete. Additionally, the use of obsolete pesticides should be avoided under all circumstances. A management plan that includes measures for the containment, storage and ultimate destruction of all obsolete stocks should be prepared in accordance to guidelines by FAO and consistent with country commitments under the Stockholm, Rotterdam and Basel Conventions.*

*Collect rinse water from equipment cleaning for re-use (such as for the dilution of identical pesticides to concentrations used for application).*

*Ensure that protective clothing worn during pesticide application is either cleaned or disposed of in an environmentally responsible manner.*

*Implement groundwater supply wellhead setbacks for pesticide application and storage.*

*Maintain records of pesticide use and effectiveness."*

#### **6.4.4 Mitigations and activities to be implemented**

Use of integrated pest management (IPM) is the most economical and environmentally safe method to reduce pest population to the economically acceptable level. Integrated pest management focuses on considering the ecosystem as a whole by combining cultural, biological and chemical methods to reach equilibrium in the production environment. IPM does not always work, mainly because intensive production is an unbalanced ecosystem by definition, and certain pests thrive well in that environment. Thus, chemical methods of control are also implemented when all integrated approaches are ineffective to reduce the population to an acceptable level or economic threshold.

No plant pest would threaten cropping if its initial population were eliminated and if individuals were not introduced into the area or recur. However, the total destruction of plant pest population is seldom achieved. Incomplete destruction of the initial population may lead to control, provided the remaining pests are few in numbers and controlled by using IPM methods and retaining natural enemy populations in the environment.

The following table lists mitigations and activities that must be implemented in order to reduce the risk of major pesticides impacts on health, wildlife and water quality.

Table 6-2 Mitigations and activities

Impact issue / Pest & pesticide threat/ risk	Mitigation Measures	Implementation tool	Expected result	Monitoring indicators	Responsibility/ Key implementing actors
Pollution of water resources and aquatic life	Control and supervise pesticide use by farmers	Adoption of IPM approaches / techniques	Farmers trained in IPM techniques	Gender and number of farmers trained, Training records	Agricultural Development Division (ADD) / SVIP
	Proper disposal of pesticide containers by resellers/farmers	Pesticide container collection and disposal plan	Pesticide container disposal plan developed and implemented	Number of farmers/ resellers aware of pesticide container disposal plan	Illovo / SVIP
	Monitor pesticides in water resources	Environmental quality monitoring plan	Pesticide concentration in water resources	Levels of pesticides in water resources	No laboratory in Malawi has capacities in pesticide detection yet
Improper use of pesticides by farmers and farm assistants	Educate farmers and farm assistants on proper use of pesticides and pesticide use hazards	Pesticide hazards and use guide manual or leaflet for the project (include simple pictorial presentations)	Proper use of pesticides by farmers and farm assistants	Gender and number of farmers trained, Training records Number of cases of pesticide poisoning occurring under the project	ADD / Illovo / SVIP
	Control and supervise pesticide use on farms	Adoption of IPM approaches/techniques	Farmers trained in IPM techniques	Gender and number of farmers trained, Training records	ADD / SVIP
	Monitor pesticide residue in crops	Random sampling procedure for crops and storage products	Pesticide residue in crops within acceptable limit/MRL	1. Levels and trend of pesticide residue in sampled crops 2. Number of times exported crops are rejected due to pesticide residues	DARTS / Research Centres
Poisoning from improper disposal of pesticide containers	1. Educate farmers, farm assistants and local communities on health hazards associated with use of pesticide containers	1. Pesticide hazards and use guide manual or leaflet for the project	Farmers, farm assistants, FBOs, local communities educated on pesticide health hazards		ADD / Illovo / SVIP

Impact issue / Pest & pesticide threat/ risk	Mitigation Measures	Implementation tool	Expected result	Monitoring indicators	Responsibility/ Key implementing actors
	2. Properly dispose pesticide containers	2. Pesticide container cleaning and disposal plan	Pesticide container cleaning and disposal plan developed and implemented	Number of cases of pesticide poisoning through use of pesticide containers; Number of farmers returning empty pesticide containers at collection points; Number of farmers, FBOs, resellers trained in proper cleaning of pesticide containers	Illovo / SVIP
Production and market losses from armyworm outbreaks	Educated and train farmers to adopt good agricultural practices	Adoption of IPM techniques/approaches	Farmers trained in IPM techniques and GAP	1. Gender and number of farmers trained, Training records 2. Production losses from crop pests	ADD / SVIP
	Establish pest surveillance system	Early detection and warning system in place	Zero or minimal armyworm cases	Incidence of armyworm cases recorded	DARTS / Research centres
	Apply EPA approved and Ministry of Agriculture recommended pesticide if necessary	Inspection of pesticides at farm/storage gate prior to use (Project Policy)	Applied pesticides registered and approved by key stakeholders and in conformity with IPM principles	Records of pesticides applied at each farm	ADD
Threat from other crop pests and diseases	Educated and train farmers to adopt good agricultural practices	Adoption of IPM techniques/approaches	Farmers trained in IPM techniques and GAP	1. Gender and number of farmers trained, Training records 2. Incidence of crop pests 3. Production losses from crop pests	ADD / Illovo / SVIP
	Apply EPA approved and Ministry of Agriculture recommended pesticide if necessary	Inspection of pesticides at farm/storage gate prior to use (Project Policy)	Applied pesticides registered and approved by key stakeholders and in conformity with IPM principles	Records of pesticides applied at each farm	ADD

Impact issue / Pest & pesticide threat/ risk	Mitigation Measures	Implementation tool	Expected result	Monitoring indicators	Responsibility/ Key implementing actors
Impact on post-harvest losses due to pests	1. Provide adequate and proper storage facilities	Post-harvest loss reduction plan based on IPM techniques in place	a.) Post harvest losses avoided or minimised b) Applied pesticides registered and approved by key stakeholders and in conformity with IPM principles	Gender and number of farmers trained in IPM techniques for post-harvest storage; Number and condition of storage facilities in use	SVIP
	2. Monitor incidence of post-harvest pests			Number of cases of post-harvest pests	ADD
	3. Confirm status and integrity of pesticides at storage gate prior to use	Inspection of pesticides at farm/storage gate prior to use (Project Policy)		Records of pesticides applied at storage sites/rooms	ADD
General health and safety of farmers/crops and environmental hazards	Educate farmers to adopt IPM techniques; and not to use chemical pesticides unless advised by Ministry of Agriculture	IPM techniques with emphasis on cultural and biological forms of pest control	Compliance with national IPM policy and WB policy on Pest/ pesticide management	Gender and number of farmers trained in IPM techniques; Number of farmers implementing IPM on their farms Frequency of chemical pesticides usage	ADD / SVIP
	Provide Personal Protective Equipment's (PPEs) to farmers/farm assistants for pesticide use in the fields	Health and safety policy for farm work	Farmers and accompanying dependants (children) protected against pesticide exposure in the fields	Quantities and types of PPEs supplied or made available under the project	ADD
	Educate farmers/ farm assistants in the proper use of pesticides	Pesticide hazards and use guide manual or leaflet for the project (include simple pictorial presentations)	Farmers know and use pesticides properly; pesticide hazards and use guide leaflet or flyers produced	Gender and number of farmers trained in pesticide use; Number of farmers having copies of the pesticide hazard and use guide flyers;	ADD / Illovo / SVIP
	Properly dispose obsolete and unused pesticides	Obsolete and unused pesticide disposal plan	obsolete and unused pesticide disposal plan prepared and implemented	Relationship between pesticide supply and usage	Illovo / SVIP

Impact issue / Pest & pesticide threat/ risk	Mitigation Measures	Implementation tool	Expected result	Monitoring indicators	Responsibility/ Key implementing actors
	Educate farmers to obtain or purchase quantities of pesticides required at a given time and to avoid long term storage of pesticides	Pesticide use policy/plan	Only pesticides needed are purchased; long term storage of pesticides by farmers avoided	Relationship between pesticide supply and usage	Illovo / SVIP
	Provide emergency response to pesticide accidents and poisoning	Emergency response plan	Pesticide accidents and emergencies managed under the project	Number of pesticide accidents and emergencies	ADD

## 7. MONITORING INTEGRATED PEST MANAGEMENT PLAN

### 7.1 MONITORING & EVALUATION

Successful implementation of a PMP requires regular monitoring and evaluation of activities undertaken by farmers in the project area. The focus of monitoring and evaluation must be to assess the build-up of IPM capacity in the command area, the extent to which IPM techniques are being adopted in crop production, and the economic benefits that farmers derive by adopting IPM.

Activities that require regular monitoring and evaluation during implementation are:

- IPM capacity building for farmers in the project area: number of farmers who have successfully received IPM training in IPM methods; evaluate the training content, methodology and trainee response to training through feedback.
- Number of farmers who have adopted IPM practices as a crop protection strategy in their crop production efforts: evaluate the rate of IPM adoption.
- In how many crop production systems is IPM applied? Are the numbers increasing and at what rate?

Activities that require monitoring and evaluation during supervision visit:

- What are major benefits that farmers derive by adopting IPM (economic and social benefits)?
- To what extent are pesticides used for crop production?
- Efficiency of pesticide use and handling.
- Level of reduction of pesticide purchase and use by farmers for crop production, compared with a baseline established before project implementation.

Efficient monitoring requires regular observation on a weekly basis, if not more frequent. Visual inspections must be made at field level for pests such as stalk borers, cutworms, disease symptoms and weeds, and their natural enemies. These practices allow the farmers to apply crop management measures early, thus preventing serious and persistent crop damages.

The main objective of monitoring plan will be to assess the adoption of various mitigation measures for pests and diseases vectors on the irrigation scheme. The plan provides decision-makers, community and farmer groups with clearer guidelines on integrated pest management plan approaches and options to reduce crop and livestock losses with minimal personal and environmental health risks. The specific objectives are:

- Design and delivery of training programme scheme farmers in appropriate use of pesticides and other environmentally friendly methods.
- Promote biological and ecological approaches for farmers to learn, test, select and implement integrated pest management plan options for reducing pest losses while promoting biodiversity, monitoring to serve as early warning systems on pest status, alien invasive species, beneficial species, and migratory pests.
- Monitor and evaluate the benefits of IPM including its impact of food security, the environment and health.

## 7.2 IPM IMPLEMENTATION TEAM

Transition to an IPM program requires a diverse, action-oriented IPM Committee. This IPM Committee will be an environmentally conscious Committee and will be part of the District Development Committee lead by the District Agricultural Development Officer (DADO) as a member of the District Development Committee (DDC). A representative of the Farming Group will be a member of this Committee. The leader of this team should be familiar with pests, pesticides and pesticide regulations. It is recommended that the leader is a member of SVIP implementation team. This arrangement is appropriate, because implementation of an IPM program can be tracked as a performance indicator.

IPM leadership is guided by pest management principles and environmental issues. Leadership with such academic background qualifies to serve as an authority to supervise IPM implementation. Other team members could include Environmental District Officer (EDO), agronomists, crop protection experts (entomologists, pathologists) and District Health Officer (DHO).

The IPM Committee will set measurable objectives and refine the IPM indicators to be relevant to their district. The initial step will be to establish an implementation timeline that includes time to execute all of the steps outlined in the implementation plan. It is imperative to include time to organize the administration of the IPM and conduct any farmer training as well as manage the IPM process.

**Figure 7 : Proposed Service Unit for SVIP**

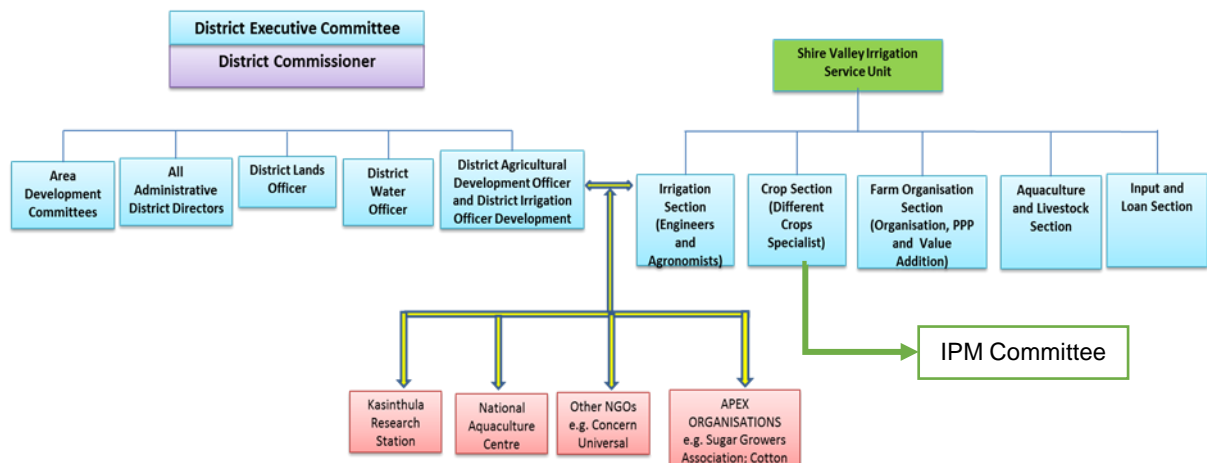

Source: AgPS adapted BRLi.



### 7.3 CAPACITY BUILDING PROGRAMME

Integrated Pest Management methods require considerable training of stakeholders especially farmers. SVIP will support training activities for farmers in irrigation schemes, training of extension workers and district agriculture and irrigation staff to support the implementation of the various methods. Capacity building will be achieved through farmer-based collaborative management mechanisms where all key stakeholders shall be regarded as equal partners whose role will be to facilitate the process and provide technical direction and any other support necessary for the implementation of the activities. Project management team will prepare a comprehensive training manuals, brochures and leaflets on pesticide use and management, targeting different actors within the program, ranging from extension service providers, actual farmers, loaders, mixers, transporters, government staff among others. The training manual or guides to be developed for use must be simplified and easy to understand and participatory in nature with in-built and demonstration/practical sessions as much as possible. Such trainings will be crop based with farmers being organized into groups led by extension workers.

Partners in capacity building and training will include the following:

- Research and training institutions: Agricultural research stations will formulate proposals for research and training programmes for the development of IPM protocols, and training modules for the IPM for IPM Committee and ASWAp-SP.
- Agriculture Services Providers and NGOs that are providing services to farmers and improving agricultural productivity, environmental management and rural health matters will be identified to provide services and technical support in the implementation of IPM
- Independent experts for specific thematic (entomologist, virus specialist, ...).

The table below present the different activities of the training action plan:

**Table 7-1 : training activities**

N°	Activity	Start date	End date	Responsibility	Target
1	Training of staff in the life cycle management of pesticides covering selection, usage and safe disposal of containers as well as chemical formulation and dosing (dilution of chemicals for use), calibration of equipment, spraying procedures and other factors to consider, handling of sprayers as well as general equipment maintenance. Trainees should be sensitised enough to use only pesticides with authentic and clear labels showing all the necessary information including expiry dates, occupational/public health and safety as well as basic environmental safeguards. This will also help avoid adulteration and sale of expired herbicides.	Year 1	Year 5	IPM Committee	IPM Committee, Extension advisors, Research station staff, Farmers
2	Provision of training and sensitisation programs in IPM including demonstrations and preparation of IPM implementation Manuals and Guidelines	Year 1	Year 2	IPM Committee	IPM Committee
3	Training/Sensitisation in the use of personal protective equipment, treatment of any pesticide poisoning, interpretation of material safety data sheets and labels on pesticide containers and safe storage of pesticides	Year 1	Year 5	IPM Committee	Extension advisors, Farmers
4	Training in First Aid and Emergency Response with a focus on treatment of chemical poisoning and pesticide spill management	Year 1	Year 5	IPM Committee	Extension advisors, Farmers

5	Sensitisation on weather and other environmental related considerations insecticide application e.g. avoiding spraying when it is about to rain, when it is windy, when it is too hot or when the soil is wet or in ponded areas or areas close to water sources (e.g. rivers, wells, etc.) and populated areas.	Year 1	Year 5	IPM Committee	Extension advisors, Farmers
---	--	--------	--------	---------------	-----------------------------

Training will be provided in both formal and informal settings including Field Days as appropriate in meeting the specific training objectives. A training needs assessment would help in setting the training agenda and ensure that the training sessions are relevant and tailored to answer to farmers' pressing information needs.

## 7.4 INSTITUTIONAL ARRANGEMENTS

Effective supervision and monitoring of implementation of IPM will be done through the IPM Committee.

At the District level, the District Development Committees, through the District Agricultural Officers, will assist the farmers to form the Farmer Groups through whom IPM activities will be implemented. The District Agricultural Officer will provide the technical assistance to the Farmer Groups.

The Agricultural Development Divisions (ADD's) will backstop the District Development Committees and assist them with the technological advancements in IPM development. They will coordinate with research institutions and organise field days to disseminate the information.

The MoAFS will provide logistical and technical support to the ASWAp-Support Project. They will thus provide capacity and policy guidance and oversight for implementation of the IPM. MoAFS will, through the ASWAp-SP, provide the overall monitoring of the IPM activities. The MoAFS and the respective districts will provide staff for training local farmers and play a major role with NGOs/CBOs in the public awareness campaigns, production of extension materials, radio and television programs in the respective districts.

Agricultural sector departments have the national mandate in the implementation of crop protection and pest management research. They will provide technical support to ASWAp-SP and IPM Committee, through the respective Agricultural Development Divisions, in the implementation of IPM.

ASWAp-SP and IPM Committee will undertake to build the capacities of researchers to train farmers and community leaders in promoting IPM activities. They will also facilitate information sharing with local farmers.

The Pesticides Control Board will provide the necessary information on pesticides and train the Farmer Groups in all aspects of pesticides including application rates, methods, storage and disposal of residues. They will also monitor pesticides stocks and potency at the dealers.

The Ministry of Health (MoH): through the District Health Officers, will set up databases on incidence of poisoning, effect of pesticides on human health and environmental contamination. This data will then be used to measure and validate the ameliorating effects of IPM adoption and implementation that is expected to reduce risks to pesticides exposure.

The Environmental Affairs Department (EAD): through the Environmental District Officers, will conduct environmental monitoring in relation to IPM. EAD will contribute towards training the beneficiary Farmer Groups in environmental pest management.

Scheme's farmers association in irrigation schemes will act as the forum to discuss general pest problems, make decisions about integrated pest management activities and facilitate networks within and between Farmer Groups. IPM Committee will develop Integrated Pest Management packages in collaboration with district agriculture officials and extension workers who will provide technical support to irrigation schemes, including identifying crop protection issues, integrated pest management training and field visits to other irrigation schemes.

## **7.5 INDICATIVE BUDGET FOR PMP IMPLEMENTATION**

The costs of PMP implementation will depend on the scale and details of the programme eventually agreed. Indicative costs for typical activities are given in the following table for a total cost of 199,000 USD.

**Table 7-2 : Indicative Budget for PMP Implementation**

	Activity/Programme	Budget USD						
		Year 1	Year 2	Year 3	Year 4	Year 5	Total	Cost/yr
<b>1</b>	<b>Capacity Building</b>							
1.1	Orientation workshops (on PMP IPM and for project registered agro-input dealers)	6 000	4 000	3 000	3 000	3 000	19 000	3 800
1.2	Training of trainers	6 000					6 000	1 200
1.3	Farmer group training	15 000	10 000	8 000	8 000	8 000	49 000	9 800
1.4	Study visits	2 000	2 000	2 000	2 000	2 000	10 000	2 000
	<i>Sub total</i>	<i>29 000</i>	<i>16 000</i>	<i>13 000</i>	<i>13 000</i>	<i>13 000</i>	<i>84 000</i>	<i>16 800</i>
<b>2</b>	<b>Support/Advisory services</b>							
2.1	Registration of pesticide suppliers	2 000	2 000	1 000	1 000	1 000	7 000	1 400
2.2	IPM problem diagnosis	8 000	6 000	4 000	4 000	4 000	26 000	5 200
2.3	Field guides/ IPM materials	7 000	4 000	2 000	2 000	2 000	17 000	3 400
2.4	Public awareness/ sensitization campaigns	4 000	3 000	2 000	2 000	2 000	13 000	2 600
2.5	Pest / vector surveillance	5 000	5 000	5 000	5 000	5 000	25 000	5 000
2.6	Laboratory analysis support-MRLs	4 000	4 000	4 000	4 000	4 000	20 000	4 000
2.7	Emergency response support	2 000	2 000	1 000	1 000	1 000	7 000	1 400
	<i>Sub total</i>	<i>32 000</i>	<i>26 000</i>	<i>19 000</i>	<i>19 000</i>	<i>19 000</i>	<i>115 000</i>	<i>23 000</i>
	<b>GRAND TOTAL / USD</b>						<b>199 000</b>	<b>39 800</b>

“Note: PMP project management duties, including PMP coordination, monitoring and evaluation, and reviews and reporting, shall be carried out by the Environmental Safeguards Specialist that is to be contracted as part of the SVIP Project Management Unit under the MoAIWD”.

# APPENDICES

## **Appendices 1. Bibliography**

Name of document	Author	Date
Government of Malawi - SVIP. Formulation of the Agricultural Development Planning Strategy. Agronomic Diagnostic and Market Opportunity Analysis. Draft Preliminary Report on Potential Crops	PWC	2015
Government of Malawi - SVIP. Formulation of the Agricultural Development Planning Strategy. Volume I: Draft Agricultural Development Planning Strategy Report. July 2016	PWC	2016
Environmental and Social Impact Assessment of about 20,000 ha Irrigation and Drainage Schemes at Megech Pump (at Seraba), Ribb and Anger Dam	BRLI	2013
The National Atlas of Malawi	Government of Malawi	1983
Government of Malawi - CHIKHWAWA DISTRICT SOCIO-ECONOMIC	Chikhwawa District Socio Economic	01/12/11
Government of Malawi - SVIP. COMMUNICATION, COMMUNITY PARTICIPATION, LAND TENURE AND RESETTLEMENT FRAMEWORK (CCPLTRF). DRAFT HOUSEHOLD QUESTIONNAIRE	Ministry of Agriculture, Irrigation and Water Development. SHIRE VALLEY IRRIGATION PROJECT	03/04/15
Government of Malawi – SVIP. Options Assessment Report (Draft). Technical Feasibility Study on (SVIP)	Dasan Consultants co	31/01/2016
Procedure For Environmental And Social Review Of Projects	IFC (The International Finance Corporation)	01/12/98
Ministry of food and agriculture project (GCAP) – Pest management plan (PMP) – Final Report	Republic of Ghana	01/11/2011
Globally harmonized system of classification and labelling of chemicals (GHS)	United Nations	2011
Government of Malawi - Ministry of agriculture and Food Security. Guide to Agricultural Production and Natural Resources Management	Government of Malawi	2003
Good management practices manual for the cane sugar industry (Final)	IFC (The International Finance Corporation)	2011
IFC Performance Standards on Environmental and Social Sustainability	IFC (The International Finance Corporation)	01/01/12
ILLOVO SUGAR (MALAWI) LIMITED ANNUAL REPORT 2015	ILLOVO SUGAR	2015
Illovo Sugar Malawi Socio-economic Impact Assessment. Internal Management Report	CORPORATE CITIZENSHIP	01/04/14
Malawi floods emergency recovery project (MFERP) – Integrated Pest Management Plan (IPMP)	Government of Republic of Malawi	01/09/15
OP 4.09 - Pest Management - These policies were prepared for use by World Bank staff and are not necessarily a complete treatment of the subject.	World Bank	01/12/98
Environmental, Health and Safety Guidelines for Pesticide Handling and Application	IFC (The International Finance Corporation)	01/06/98
The WHO Recommended Classification of Pesticides by Hazard and Guidelines to Classification 2009	IPCS / IOMC	2009
Prohibited Materials List	FAIRTRADE INTERNATIONAL	15/05/14
SAN Sustainable Agriculture Network – Sustainable agriculture Standard	SAN Sustainable Agriculture Network	01/06/10
Taking Root Fairtrade in malawi. A synthesis report by Barry Pound and Alexander Phiri Natural Resources Institute, University of Greenwich	Fairtrade Foundation	01/04/11
Weed Identification and Knowledge in the Western Indian Ocean	CIRAD / IFP / FOFIFA / MCIA / CNDRS / EUROPE / ACP / ACP SAT PROGRAMME / SAPIENS NIHIL AFFIRMAT QUOD NON PROBET	2013

## **Appendices 2. Persons contacted**



No	ORGANISATION	NAME	CONTACT DETAILS	Tel
<b>Public institutions</b>				
1	MoAWID: Chief irrigation officer	Charles Mwalabu	mwalabu2005@yahoo.co.uk	999569992 884131006
2	MoAWID: Director of irrigation services	Geoffrey Mamba	mamba.geoffrey5@gmail.com	888891821
3	MoAWID: Deputy Director of Irrigation Services (planning&Design)	Chawanangwa Kajiso Jana	chawanangwakajiso@yahoo.co.uk	265 1752122 265 999276327 265 884 439 872
4	Waterboard Blantyre	Boukar Waya/Miss Mateyou		882696771
5	District irrigation task force: Irrigation Engineer	Dennis Chalera	dkchalera@gmail.com	991 634 826
6	ADD Ngabu	Mr Mvula	jmdzucu@yahoo.com	
7	ADD Chikwawa	Duncan Magwira	duncanmagwira@yahoo.co.uk	
8	Irrigation district Chikwawa: Irrigation Engineer	Daniel		999382458
9	PPP Commission: Director, Project Development & Transactions	Jimmy Lipunga or Charlie Msusa	jlipunga@pppc.mw ; msusa@pcmalawi.org	999 950 767
10	SVIP Coordinator	Rodrick Champiti	champitir@gmail.com	0888865290 999865290
<b>SVIP main stakeholders/potential private sector candidates</b>				
11	Ilovo: Fields Manager	Watson Ligomba	wligomba@gmail.com wligomba@ilovo.co.za	999610207 888310207
12	Ilovo: Malawi Managing Director	Ray de Allende		992771800
13	Ilovo: Agriculture Manager	Keth Domleo	kdomleo@ilovo.co.za	999956658
14	Ilovo: Agriculture Manager	Philipp Ashton	pashton@ilovo.co.za	
15	Majete Wildlife Reserve: Park Manager	Craig Hay	craigh@african-parks.org	(265) 999 965028
16	Kasinthula Research Station	Dr Fandika		0882925512
17	Kasinthula Research Station	Chilango Tom		999557618
18	Kasinthula Research Station	Gongwe Dokotala		999346030
19	KRC : technical study	JO Jin-Hoon	jojinhoon@hanmail.net	998311827
20	Kasinthula outgrowers: General Manager	Masauko Khembo	mkhembo.kcgl@kasinthula.mw	2651420320 265993334033 265888334033
21	Kasinthula Outgrowers : Field manager	Lallior Nakhupe	Lnakhupe.kcgl@kasinthula.mw	0999564210

## **Appendices 3. FAO Guideline on Management Options for Empty Pesticide Containers**



# International Code of Conduct on the Distribution and Use of Pesticides

## Guidelines on Management Options for Empty Pesticide Containers



**World Health  
Organization**



FOOD AND AGRICULTURE ORGANIZATION  
OF THE UNITED NATIONS

MAY 2008

The Inter-Organisation Programme for the Sound Management of Chemicals (IOMC) was established in 1995 following recommendations made by the 1992 UN Conference on Environment and Development to strengthen cooperation and increase international coordination in the field of chemical safety. The participating organizations are the Food and Agriculture Organization of the United Nations (FAO), the International Labour Organization (ILO), the Organisation for Economic Co-operation and Development (OECD), the United Nations Environment Programme (UNEP), the United Nations Industrial Development Organization (UNIDO), the United Nations Institute for Training and Research (UNITAR) and the World Health Organization (WHO). The World Bank and the United Nations Development Programme (UNDP) are observers. The purpose of the IOMC is to promote coordination of the policies and activities pursued by the participating organizations, jointly or separately, to achieve the sound management of chemicals in relation to human health and the environment.

This publication was developed in the IOMC context. The contents do not necessarily reflect the views or stated policies of individual IOMC participating organizations.

The designations employed and the presentation of material in this publication do not imply the expression of any opinion whatsoever on the part of the Food and Agriculture Organization of the United Nations (FAO) or of the World Health Organization (WHO) concerning the legal status of any country, territory, city or area or of its authorities, or concerning the delimitation of its frontiers or boundaries. The mention of specific companies or products of manufacturers, whether or not these have been patented, does not imply that these are or have been endorsed or recommended by FAO or WHO in preference to others of a similar nature that are not mentioned. The published material is being distributed without warranty of any kind, either expressed or implied. The responsibility for the interpretation and use of the material lies with the reader. In no event shall FAO or WHO be liable for damages arising from its use. The views expressed herein are those of the authors and do not necessarily represent those of FAO or WHO.

E-ISBN 978-92-5-106832-8 (PDF)

All rights reserved. FAO and WHO encourage the reproduction and dissemination of material in this information product. Any proposed reproduction or dissemination for non-commercial purposes will be authorized free of charge upon request, provided the source is fully acknowledged. Any proposed reproduction or dissemination for resale or other commercial purposes, including educational purposes, is prohibited without the prior written permission of the copyright holders, and may incur fees. Applications for such permission and all other queries on rights and licences, should be addressed by e-mail to [copyright@fao.org](mailto:copyright@fao.org) or to the Chief, Publishing Policy and Support Branch, Office of Knowledge Exchange, Research and Extension, FAO, Viale delle Terme di Caracalla, 00153 Rome, Italy.

## Table of contents

Abbreviations.....	1
Definitions .....	2
1 Introduction.....	3
1.1 Pesticide containers .....	3
1.2 Intrinsic value of containers.....	6
1.3 Reuse of one-way containers .....	6
1.4 The waste management hierarchy.....	6
1.5 Cleaning containers.....	8
1.6 Disposal at the place of use .....	16
1.7 Stakeholder involvement .....	16
2 Assessment of the nature and scale of the issue .....	17
2.1 Other agricultural packaging .....	19
3 Mechanisms for developing a container management scheme .....	19
3.1 Legal basis .....	19
3.2 Economics and incentives.....	21
3.3 Infrastructure and logistics .....	22
3.4 Countries with low pesticide use .....	26
4 Farmers and other uses of pesticides .....	26
5 Pre-processing .....	27
5.1 Volume reduction .....	27
5.2 Material segregation .....	28
6 Recycling and Disposal.....	28
6.1 Recycling into new products.....	28
6.2 Resource Recovery .....	30
6.3 Disposal .....	31
7 Examples of schemes .....	31
7.1 Australia.....	32
7.2 Belgium.....	32
7.3 Brazil.....	33
7.4 Canada .....	34
7.5 Chile.....	35
7.6 France.....	36
7.7 Guatemala .....	37
7.8 Germany.....	38
7.9 Hungary.....	39
7.10 USA.....	39
7.11 Performance of container management schemes around the world.....	40
8 References and further information .....	42

---

## **Definitions**

**One-way pesticide container.** Containers that should not be reused or refilled once the contents have been deployed.

**Primary packaging.** Packaging that is in direct contact with the pesticide.

**Secondary packaging.** Packaging that protects the primary packaging. Secondary packaging does not normally come into contact with the pesticide.

**Rinsate.** The contaminated rinse liquid once it has been used to rinse a container.

# Guidelines on Management Options for Empty Pesticide Containers

## 1 Introduction

This guideline provides advice on the management of one-way pesticide containers following the deployment of their contents. Unless empty pesticide containers are managed correctly, they are hazardous to both mankind and the environment. There is a danger that empty containers could be reused for storing food and water, which could result in pesticide poisonings. Containers abandoned in the environment can lead to pesticide pollution in soil and groundwater. A container management scheme can minimize these risks and is part of the “life-cycle concept” as addressed in the *International Code of Conduct on the Distribution and Use of Pesticides* [1].

A container management scheme should ensure that:

- the containers are decontaminated directly following the use of their contents;
- inappropriate use of the empty containers is prevented; and
- it is easy for users to return their empty containers to the scheme.

The safety of pesticide users and the public is of paramount importance when designing a container management scheme.

Successful container management schemes around the world have been achieved only with the engagement and support of all stakeholders in the supply chain for pesticides. These stakeholders include government bodies, manufacturers, users, distributors and suppliers, recyclers and disposers, NGOs and trade unions. This guideline identifies how each of these stakeholders can contribute to a container management scheme. The guideline considers the role of manufacturers in the design of the containers and the formulation of the product as well as their responsibility for product stewardship.

The safe and environmentally sound management of containers at the end of their life is an external cost to the marketing and use of pesticide products. As such, the container management scheme should bear these costs. The scheme will require adequate funding to support all its operations and the environmental management of the empty containers. It is the choice of the government how the scheme should be structured and funded. Options include general taxation, levies on the manufacturers and importers, deposits, or fees. These options are discussed in more detail in section 3.2.1.

The issue of legacy stockpiles of old containers contaminated with pesticide residues is addressed in FAO’s *Guideline on the Disposal of bulk quantities of obsolete pesticides in developing countries* [2], of which a revised version is due to be published to avoid any duplication with this guideline.

### 1.1 Pesticide containers

The design of a pesticide container is important. A well-designed container can help to:

- minimize the risks of leakage during transport and storage;

- minimize exposure to users; and
- minimize the burden on the environment at the end of the container's life.

Likewise, a poorly designed container is hazardous. A country should therefore regulate the design of the container as well as the pesticide formulation when it registers a pesticide product. The principal criteria for a well-designed container are:

- to contain the product and prevent its contents escaping during storage and transport;
- to protect the pesticide product from impairment due to the conditions under which it is distributed and stored;
- to allow the product to be transferred into its application system without endangering the health of users or the environment;
- to minimize the burden on the environment from the management of the container, once the contents have been deployed.

In assessing a container, the registration authorities should consider whether it meets the criteria for storage, transportation and use. Provided it satisfies these criteria, the registration authorities should then consider the criteria for minimizing the environmental burden of the recycling or disposal of the empty container at the end of its life.

#### *Design criteria for storage, transport and use*

A container can satisfy the criteria for safe storage, transport and use when:

- it complies with the UN packaging codes;
- it is constructed from materials that are inert, that are impermeable to the contents, and to which pesticides and rinsing liquids do not adhere;
- it is sufficiently robust to withstand the hazards of distribution and storage;
- it is liquid tight and has a resealable cap;
- it is easy to handle by users;
- it pours accurately and smoothly without dripping or glugging;
- it can be completely emptied by avoiding features that trap the contents;
- it is labelled appropriately;
- it has an easy method to identify the amount of pesticide remaining in the container, e.g. translucent container walls; and
- it is easy to rinse.

A container that can be emptied fully and easily rinsed has an economic benefit to the user so that the entire contents are available for use against its target pest. An empty rinsed container also represents a lower hazard to the public and environment.

#### *Design criteria for minimizing the environmental burden of the recycling or disposal of the empty container*

Provided that the safety criteria have been satisfied, the environmental burden of the recycling or disposal of the empty container should be assessed. Minimizing the ratio of the weight of the empty container to that of a full one will reduce the overall quantity of material to be recycled or disposed of



at the end of the container's life. The choice of the materials from which the container is constructed has a bearing on its recyclability. Ideally containers should be made from a single type of material. This avoids the need for expensive processes to break it down into its constituent components during the recycling process. This is particularly an issue with a container made from more than one type of plastic.

### *Labelling*

The container label plays a vital role in communicating information about the pesticide, its hazards, safety information and its use. International regulations, such as the *European agreement concerning the international transport of dangerous goods by road* (ADR) [3], FAO codes and the newly adopted *Globally Harmonized Systems of Classification and Labelling of Chemicals* (GHS) [4], set out standards for the design and content of the label. Containers should also have labels with information about how they should be cleaned and disposed of following their use.

As part of a country's pesticide registration process, the standard of containers allowed to enter the market can be strictly controlled to ensure that these design and labelling requirements are met.

#### 1.1.1 Alternatives to one-way containers

The most common form of packaging used for pesticides is the one-way container, which needs to be managed after the deployment of its contents. However, there are alternative container designs that have been developed to avoid the necessity of recycling or disposing of the empty containers, including reusable/refillable containers and water soluble containers.

#### *Refillable Containers*

Refillable containers have been developed for pesticide applications where there is a large and regular demand and the products are used relatively close to where the containers can be refilled. Refillable containers are therefore only appropriate in a very few cases. The potential advantage of using reusable/refillable containers is that they avoid the manufacturing cost of a new container and the cost of their disposal after each deployment. There are issues that need to be considered with reusable containers including:

- the long-term permeation of the pesticide into the container material;
- the long term integrity of the container and label;
- build-up of residues after repeated use and refilling;
- separation or crystallization; and
- homogeneity of the residues and the product to be refilled.

Refillable containers should only be refilled with the same formulated pesticide product to avoid the risks of cross-contamination.

#### *Water Soluble Packs*

Soluble packaging is an option for pesticides that are diluted with water before application. The soluble sacks are put directly into the spray tank where they dissolve and release their contents. There are two main advantages:

- there is no operator exposure to the contents as the packs do not require opening; and
- there is no contaminated container to be recycled or disposed of.

The soluble container should be considered an integral component of the formulation. Soluble packs require waterproof secondary packaging to protect them from damage during their storage and distribution.

Pesticide regulations should encourage innovation in package design that improves public safety and reduces the burden on the environment.

## **1.2 Intrinsic value of containers**

Empty containers have a value in some economies for the storage of water and food, or for recycling into cookware and tools. The cost of a new 200 litre steel drum is equivalent to one month's salary for a store keeper in some regions. Without adequate control, there is the danger that pesticide containers are used for the above-mentioned purposes, thus leading to public health issues due to contaminated food and water supplies. Pesticide containers, however well cleaned, are not appropriate for the storage of water and comestibles. The container management scheme should be designed with safeguards to ensure that pesticide containers are not used in this way. Appropriate safeguards should include:

- instructions to users to immediately clean the container of its contents following use and then to physically damage it to render it unusable. Cleaning procedures such as triple rinsing are discussed in section 1.5.5. Puncturing or cutting containers are appropriate means of preventing their reuse.
- education and communications programmes, aimed at raising awareness of the dangers of using pesticide containers for storage of food and water. Examples of publicity materials are included in section 3.3.3.

## **1.3 Reuse of one-way containers**

One-way pesticide containers should not be reused or refilled once the contents have been deployed because of the potential for contamination. The only circumstance when a container may be refilled is if it is refilled with an identical product that is being transferred from a damaged container.

## **1.4 The waste management hierarchy**

The waste management hierarchy sets out an order of precedence for the selection of the most favourable waste management option. The most preferred options are those that have either no impact or minimal negative impact on the environment, while the least preferred ones have a significant negative impact. Many countries enshrine the hierarchy in their environmental legislation. The hierarchy has been used in this guideline in the selection of recommended solutions for containers. The hierarchy is shown in Figure 1 below.

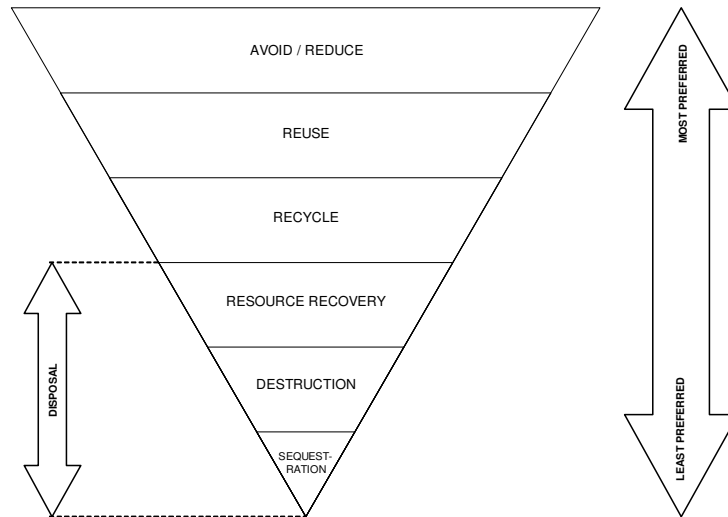

**Figure 1: Waste management hierarchy**

The following examples, moving from most preferred to least preferred options, show how the hierarchy functions.

**Avoid / Reduce**

Using fewer pesticides through adopting practices such as Integrated Pest Management (IPM) will reduce the quantity of waste containers. It also reduces the release of pesticides into the environment and has economic benefits to users. Using water soluble containers avoids generating contaminated containers.

**Reuse**

The use of closed-loop refillable containers allows the container to be used many times before it reaches the end of its life, when it has to be recycled or disposed of. Reusable containers are preferred because they avoid the environmental costs of the manufacture and disposal of several one-way containers. Reusable closed-loop containers have only limited applications, as explained in section 1.1.1.

**Recycle**

Recycling is the reprocessing of the materials from which the container was constructed into other products. Recycling does generate some environmental costs, such as energy use in reprocessing the materials, but there is no loss of the raw material. It is preferred over the options where the material is destroyed or unavailable for use.

**Resource recovery**

Use of the combustible components of the container materials as fuel in a cement kiln or power station is considered resource recovery. The container materials are destroyed but the energy is recovered and used in the process.

**Destruction**

High temperature incineration destroys containers and their pesticide contaminants, converting their chemical components into less hazardous by-products.

## Sequestration

Landfill or permanent storage of the containers are examples of sequestration. The containers still exist but their hazards are prevented from impacting public health or the environment. Sequestration can use up scarce land, making it unusable for agriculture.

## 1.5 Cleaning containers

### 1.5.1 Advantages of cleaning containers

The cleaning of containers has many advantages, therefore it should be encouraged.

The economic advantages are:

- rinsing saves money. An empty container allowed to drip into the spray tank could still contain 2 percent of its original contents. By rinsing and adding the rinsate to the tank, none of the pesticide is wasted;
- recycling or disposal of a properly rinsed container should be less expensive. The residual pesticide contamination will be sufficiently low (see sections 1.5.9 and 1.5.10) for it to be classified as non-hazardous waste.

The environmental advantages are:

- a properly rinsed container minimizes the risks of contamination to soil, surface water and ground water;
- rinsing the container immediately after emptying it reduces the chances of exposure to users, the wider public and animals;
- properly rinsed containers may be recycled into other products rather than requiring their destruction as hazardous waste.

Cleaning containers is fundamental to any management scheme for one-way containers as it reduces the hazards associated with the subsequent processes and risks to public health and the environment.

### 1.5.2 When should containers be cleaned

Cleaning should be undertaken immediately following emptying the container such that all of the product may be used for its intended purpose and any residual contamination is not allowed to adhere to the internal surfaces of the container. Pesticide residues that are allowed to harden and congeal on the surfaces of the container or its cap are much more difficult to remove. They often require physical abrasion and much more rinsing liquid. Rinsing immediately when the pesticides are still liquid is quick and easy.

### 1.5.3 Legal basis for cleaning containers

A country cannot rely on users alone to clean containers. Although the majority of users may clean their containers because it makes economic and environmental sense, there will be a proportion of users that will not clean them. To persuade this group to clean their containers, it should be made mandatory under pesticide regulations. The legal definition of an “empty container” should state that it has to be properly rinsed. A container that has not been properly rinsed should remain classified as hazardous.

#### 1.5.4 Cleaning methodologies

The cleaning methodology to be used depends on the physical and chemical characteristics of the pesticide. In all cases instructions for cleaning the container should be included in the product label and product safety data sheets. Cleaning methodologies are shown in Table 1 below.

<b>Formulation</b>	<b>Cleaning methodology</b>
Emulsifiable concentrates	Rinsing with water using the manual triple rinsing technique, pressure rinsing or integrated rinsing
Water soluble products	
Water soluble solids	
Oil and solvent based products	Rinsing with solvent

**Table 1: Cleaning methodologies**

It is important to note that an inappropriately selected cleaning methodology will be at best ineffective and at worst dangerous. For example some pesticide formulations are water reactive and, if the containers were triple rinsed, there could be a violent reaction.

The majority of one-way containers available on the market are appropriate for rinsing with water. For the sake of clarity, this guideline focuses on water rinsing as the cleaning methodology.

It is extremely important that the effective rinsing of containers takes place as soon as possible after deployment of the pesticide. In most cases this will occur at the place of deployment, e.g., on the farm. Notwithstanding how an empty container is recovered, it must be properly rinsed. This underpins all subsequent activities. The correct practice for rinsing requires the user to:

- rinse the containers immediately after emptying them;
- add the rinsate to the spray tank as part of the make-up solution.

This allows for effective removal of pesticide residues. In addition to being good agricultural practice, it makes good economic sense by ensuring that users are able to use all of the pesticide. If the rinsate cannot be added to the application equipment of the mixing tank, it may be stored for later use or disposal. Disposal should always be in accordance with FAO and WHO guidelines and national and international laws and regulations.

There are three standard rinsing options:

- triple rinsing;
- pressure rinsing;
- integrated pressure rinsing.

#### 1.5.5 Triple rinsing

Triple rinsing is the method to use in the absence of *ad hoc* mechanical rinsing equipment. It is likely to be the most practical option in developing economies. It can be used to clean all sizes of containers but the technique is slightly different for small containers that can be shaken by hand, and large containers that are too big to shake. Examples of the rinsing instructions are shown below.



(Copyrighted by Bayer CropSciences)

**Figure 2: Examples of triple rinsing**

*For containers small enough to shake:*

- empty the remaining contents into the application equipment or a mix tank and drain for at least 30 seconds after the flow begins to drip;
- fill the container ¼ full with clean water;
- securely re-close the cap;
- shake, rotate and invert the container so that the water reaches all the inside surfaces;
  - either add the rinsate to the application equipment or the mix tank; or
  - store it for later use or disposal;
- allow the container to drain for 30 seconds after the flow begins to drip;
- the procedure should be repeated at least twice more until the container appears clean.

*For containers that are too large to shake:*

- empty remaining contents into the application equipment or a mix tank;
- fill the container ¼ full with water;
- replace and tighten closures;
- tip container on its side and roll it back and forth, ensuring at least one complete revolution, for 30 seconds;

- stand the container on its end and tip it back and forth several times;
- turn the container over onto its other end and tip it back and forth several times;
- empty the rinsate into application equipment or a mix tank or store rinsate for later use or disposal. Repeat this procedure at least twice more until the container appears clean.

### 1.5.6 Pressure rinsing

Pressure rinsing equipment uses water under pressure (typically three bar) in the form of a static or rotating spray jet and valve. The jets of water hit the internal surfaces of the container removing and dissolving the pesticide residues. Some pressure rinsing equipment includes a sharp device that penetrates the container walls for rinsing purposes, thereby offering the additional advantage of making the container unusable for storage. These devices should be used in accordance with the manufacturers' instructions to avoid injury to the operator. Examples of pressure rinsing devices are shown in Figure 3 and Figure 4 below.

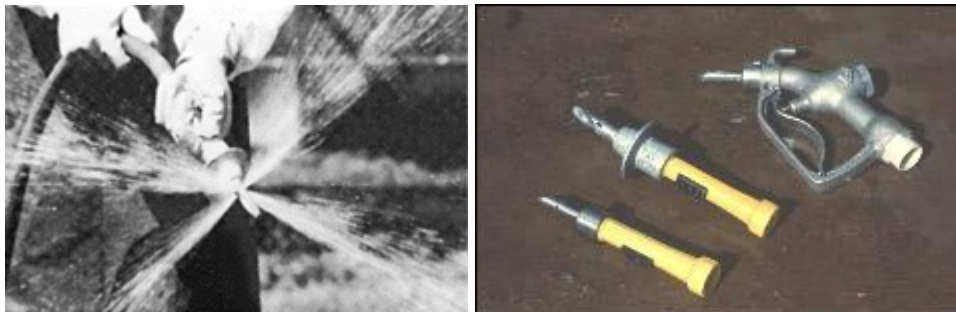

(Copyrighted by the North Dakota State University Agriculture and University Extension [5])

Copyrighted by the University of Florida, Institute of Food and Agricultural Sciences (UF/IFAS) [6] for the people of the State of Florida.

**Figure 3: Examples of pressure rinsing devices**

The procedure for pressure rinsing small containers is the following:

- put on the personal protective equipment listed on the product label;
- install pressure-rinse nozzle on hose connected to a water supply capable of delivering three bar of water pressure;
- allow formulation to drip-drain from its container into the sprayer's tank for at least 30 seconds;
- firmly press the pressure-rinse nozzle tip into the side or bottom of the pesticide container until the probe is inserted and seated, then turn on and rinse the container for at least 30 seconds with it draining into the sprayer's tank. During the rinsing, rock and rotate the nozzle so that the water jets reach all internal surfaces of the container. Make sure hollow handles are properly rinsed;

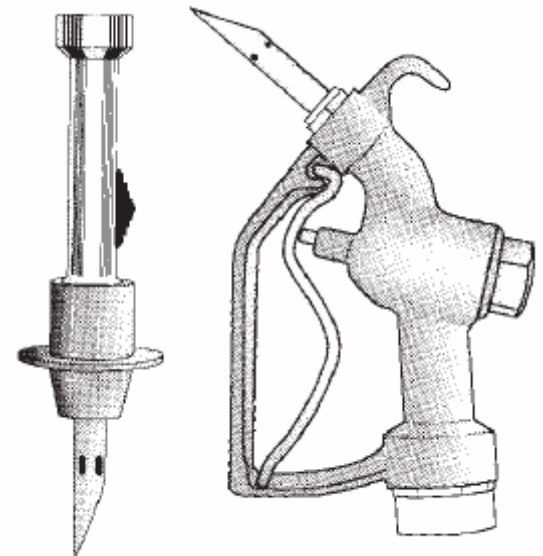

(Copyrighted by the North Dakota State University Agriculture)

**Figure 4: Pressure rinsing tools**

- allow the container to drip-drain for at least 30 seconds;
- rinse the caps by placing in a bucket of water for 3 minutes. Screw the rinsed caps back onto the container and add the water to the spray tank

NOTE: Use "rocking", twisting or "wobbling" motion to make sure spray hits bottom of container; or pierce side of container instead of bottom.

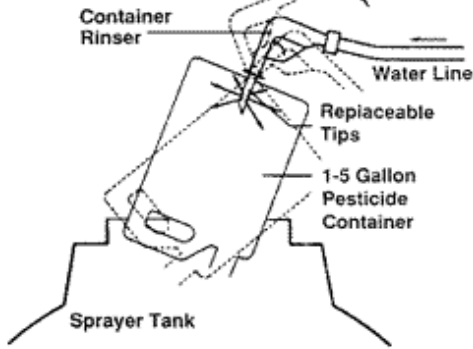

(Copyrighted by the North Dakota State University Agriculture and University Extension)



(Copyrighted by BayerCropScience)

**Figure 5: Pressure rinsing in action**

For larger containers that are too heavy to lift above the spray tank, for example 200 litre drums, a suction/rinse probe can be used with the container standing upright. A diagram of a probe is shown in Figure 6 below. The procedure for rinsing large containers is the following:

- using the probe suck the contents into the spray tank. Tilt the drum slightly so the remaining contents gather in a corner at the bottom and suck these into spray tank;
- turn on the rinsing nozzles while sucking the rinsate into the mixing tank. Rinse for 3 to 5 minutes;
- turn the rinsing nozzles off and continue to suck the rinsate into the spray tank. The drum can be tilted to enable all the rinsate to be sucked into the spray tank.

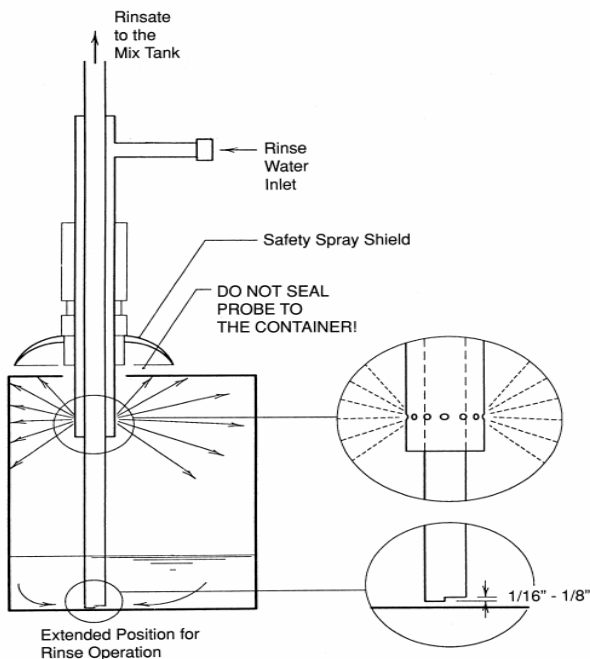

(Copyrighted by the North Dakota State University Agriculture and University Extension)

**Figure 6: Suction rinse probe for large containers**



### 1.5.7 Integrated rinsing

Integrated rinsing technology incorporates the rinsing process directly into large scale tractor-mounted spraying equipment. Wherever possible, integrated rinsing equipment should be used. Integrated rinsing is the most efficient method of rinsing containers and provides a high level of operator safety. It is also quicker than both triple rinsing and pressure rinsing. Integrated rinsing devices rinse by using water under pressure (of typically three to five bar). A static nozzle with a valve is normally built into the induction hopper of the sprayer. The water pressure cleans the container until no residues are visible (typically requiring up to 30 seconds and 15 litres of water). The rinsate is then automatically added to the spray liquid.

Integrated rinsing devices can be built into a closed chemical transfer system and can therefore provide both efficient rinsing and even greater operator safety. This avoids spillage, which may expose the operator to unnecessary risk.



(Copyrighted by BayerCropScience)



(Copyrighted by BayerCropScience)

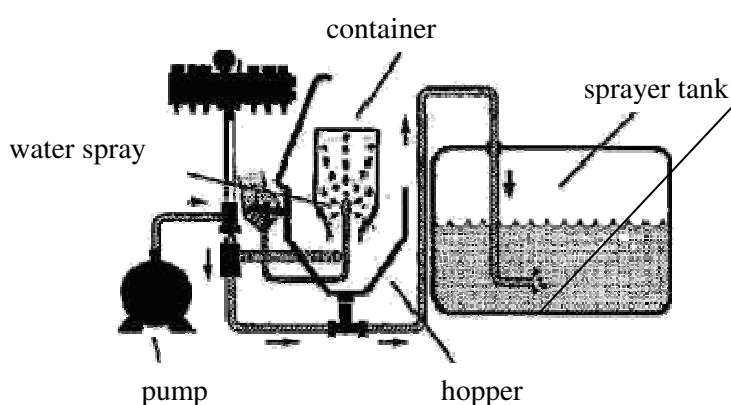

(Copyrighted by Casafe: <http://www.casafe.org/>)

**Figure 7: Integrated rinsing equipment**

Closures can be rinsed by placing them in the induction hopper. With triple rinsing, they are cleaned by the shaking process. In addition, the manufacturer's instructions should be followed when using any rinsing equipment.

Once a container has been rinsed, it should be inspected to ensure that all residues have been removed and then physically punctured or cut to render it unusable. The empty containers are then ready to be consigned to the container management scheme.

Whatever the selected method of rinsing, the rinsate should ideally be added directly to the spray solution. In the case where the next application is planned in the near future and provided that the pesticide formulation has not exceeded its expiry date, the rinsate can be stored for this future use. The storage containers should be labelled appropriately. Where there is no future need or the formulation cannot be guaranteed to be within specification, the rinsate should be legally disposed of in accordance with the FAO guidelines.

### 1.5.8 Solvent rinsing

For pesticides that are formulated in a solvent or oil and are not water soluble or dispersible, the rinsing process has to use a solvent as the rinsing medium. Solvent rinsates may not be suitable for adding to the formulated product for application, in which case they have to be treated as pesticide waste and be disposed of in an environmentally sound manner.

#### *Automated solvent rinsing and drum crushing*

Automated equipment is available for rinsing containers that had contained oil and solvent based pesticides. Such equipment has been used effectively to clean and crush the empty containers resulting from campaigns to control Desert Locusts. The process steps are:

- empty container is placed inside the unit, and the doors sealed;
- the drums are punctured by the solvent sprayers;
- solvent is sprayed inside the drum;
- solvent is extracted from the drum;
- clean drum is crushed;
- the solvent is reused until pesticide concentrations build up;
- the contaminated solvent is disposed of as pesticide waste.

Figures 8 below shows solvent washing and crushing equipment.



(Copyrighted by FAO)

**Figure 8: Automated solvent washing and crushing equipment**

### 1.5.9 Performance of rinsing techniques

Tests have been undertaken to demonstrate the effectiveness of triple rinsing as described above. Table 2 below shows the result of an experiment to determine the quantity of an active ingredient remaining in a container at each of the stages in triple rinsing.

<b>Active ingredient in 1 oz (28g) of liquid remaining in a 5 gallon (22.5L) container</b>		
<b>Rinsing stage</b>	<b>Pesticide residue</b>	<b>Percentage remaining</b>
After draining	14.2 g	100.0%
After 1st rinse	0.2 g	1.4 %
After 2nd rinse	0.003 g	0.021 %
After 3rd rinse	0.00005 g	0.00035%

**Table 2: Rinsing statistics**

(Source: Pest Management Principles for the Wisconsin Farmer)

### 1.5.10 Waste classification for rinsed containers

Countries should address the issue of waste classification of rinsed containers either as “hazardous waste” or “non-hazardous waste”. The decision can make a significant difference to the costs and administrative burden of the container management scheme. In Europe, if empty containers are classified as “hazardous waste” their transportation is tightly controlled and subject to regulatory charges. International transboundary movements would likewise have to be subject to the procedures of the Basel Convention [7]. Recycling and disposal options are more costly and fewer for containers classified as hazardous waste.

In Germany the cost differential between managing empty containers as hazardous and non-hazardous has been estimated at €0.60 per kilogram of empty container [18].

Cleaned pesticide containers are classified in many European and North American countries as “non-hazardous” waste. However there are exceptions such as Spain, France and Ireland where they are classified as “hazardous”.

The European Waste Catalogue<sup>1</sup> [9] provides guidance on classification of “packaging containing residues of or contaminated by dangerous substances”. Where the concentration of the highly hazardous component is less than 0.1 percent, the packaging is classified as “non-hazardous”. Studies undertaken in Canada have analysed the residual contamination in triple rinsed containers from 40 different highly hazardous pesticide products. The studies have investigated the contamination that adheres to the container surface and has permeated into the container materials. These studies show that the overall concentration in the container falls below 0.1 percent (source CropLife International).

FAO/WHO recommend that countries should classify properly rinsed containers that have been inspected as non-hazardous.

### 1.5.11 Comparison of rinsing techniques

Triple rinsing and pressure rinsing, when undertaken to the standards set out in these guidelines are able to clean containers so that the containers should be classified as non-hazardous waste. Table 3 below shows the principal differences between the two procedures.

---

<sup>1</sup> European Waste Catalogue number 15 01 10\*

<b>Features</b>	<b>Pressure Rinsing</b>	<b>Triple Rinsing</b>
Number of Steps	8	17
Time Spent per Container	1 - 2 min.	4 - 9 min.
Container Types Rinsed	All	All
Special Equipment Needed Rinse	Nozzle/high pressure water	None

**Table 3: Comparison of triple and pressure rinsing**

Cleaning a container by triple rinsing involves twice as many steps and takes about four times as long as pressure rinsing. However it does not need any special equipment. Triple rinsing is likely to be the preferred technique where pesticide usage is low and there is limited availability of special equipment. Pressure rinsing is likely to be the preferred option in locations where there is intensive agriculture.

## **1.6 Disposal at the place of use**

FAO/WHO recommend that the practice of disposal of pesticide packaging at the place of use by burying or burning be prohibited.

### **1.6.1 Burning of containers**

Burning plastics and pesticides in an uncontrolled fire will not destroy the hazardous components completely and may generate environmentally persistent toxic emissions. The only thermal processes that are able to destroy plastics and pesticides are licensed high temperature incinerators and cement kilns with effective emission controls. Pesticide products should never be burnt at the farm or any other place of use. Countries should apply the precautionary principle and should regulate to prevent such burning of all primary packaging, whether cleaned or not.

### **1.6.2 Burial of containers**

Burying rinsed pesticide containers at the place of use is not an ideal solution. It potentially uses up scarce land and can be a danger to animals. Plastic containers are highly stable and do not biodegrade, so, if buried, they will remain intact indefinitely. Burying containers is not easy because the void space inside them and their low density cause them to rise gradually to the surface of the soil. As such, burying at the place of use is not a viable solution. Countries should regulate against burial of all containers and develop a container management scheme that makes it easy for all users to return empty containers.

### **1.6.3 Disposal of Secondary packaging**

Clean secondary packaging, such as pallets and outer cardboard cartons, which has not come into direct contact with pesticides can be assumed to be uncontaminated. This can be disposed of as municipal waste. Material recycling and energy recovery are the disposal routes of choice but if neither option is available, the secondary packaging may be disposed of as municipal waste.

## **1.7 Stakeholder involvement**

For a successful container management scheme it is important to engage and involve all stakeholders. These include:

- governments and their agencies whose responsibility it is to set up and to regulate the legal framework for pesticide registration, pesticide use and disposal of waste materials, and to determine the mechanisms for funding the scheme;
- manufacturers, importers and suppliers who are responsible for compliance with pesticide and waste regulations, good practice in product and container design, product stewardship throughout the supply chain and who, in many cases, fund and manage the container management scheme;
- users, whose responsibility it is to manage and use pesticide products in a safe, legal and responsible way, including the return of the empty containers for appropriate recycling/disposal;
- NGOs, agricultural colleges and schools, extension services, farmer cooperatives and associations who are well placed to raise awareness of good practice in pesticide use, and in some cases to run container management schemes;
- waste management and recycling organizations.

When a country wishes to establish a container management scheme, it should consult widely and involve these stakeholders in the development of the scheme. Establishing a steering committee and stakeholder forum early in the process should be a priority. Further guidance can be found in FAO's Code of Conduct [1] and FAO's Country Guidelines [19].

## **2 Assessment of the nature and scale of the issue**

To evaluate the options for developing a container management scheme, the first step is to assess the types and quantities of the pesticide containers that it will have to manage. The Stakeholder Forum should be able to provide the information necessary for making the assessment.

The assessment should start with a review of pesticide information that is available within existing registration, customs records and other data collection systems. Where necessary, this can be augmented with surveys of the pesticide market. The objective of the review is to assess the geographic distribution, types and quantities of containers that are supplied to users. Manufacturers, importers, formulators, repackers and distributors will be able to provide this information. Customs authorities will be able to provide information on imported pesticides. User associations may be able to provide information about pesticide usage patterns.

Understanding the way that the supply chain functions is important, particularly when determining the opportunities to use it as a potential reverse distribution mechanism for collecting empty containers. An example of a supply chain is shown in Figure 9 below.

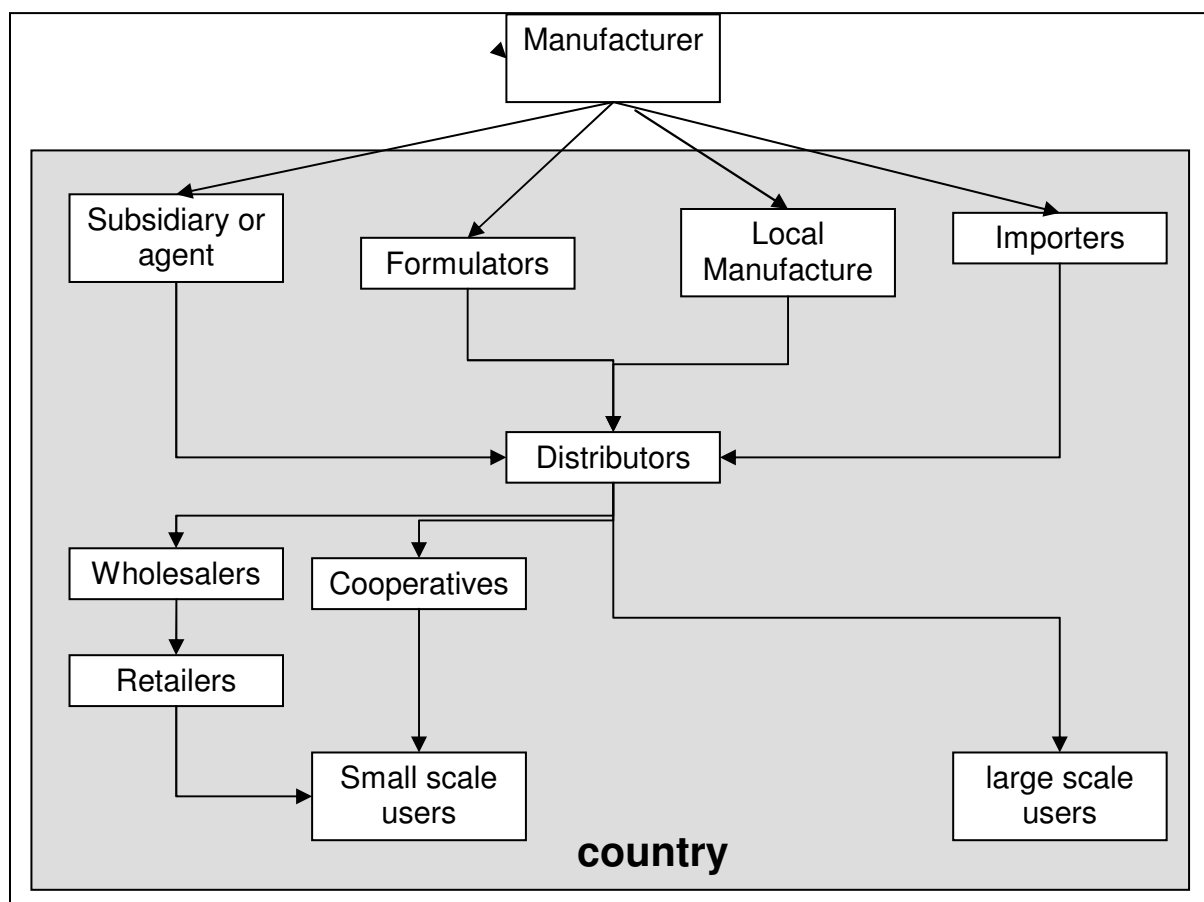

**Figure 9: Sample supply chain**

In evaluating the supply chain, it is important to explore all the potential paths that a pesticide product could take before it arrives at a user. In some economies, it could also be necessary to consider those pesticides that are distributed illegally. In such cases, methods for their regulation and control should be developed.

At the end of the survey the country should attempt to quantify the various packaging materials put onto the market as set out in Figure 10 below.

Type of container	Material	Quantity/kilos)
Metal	Steel	
	Aluminium	
	<b>Total metal</b>	
Rigid plastic	High-density polyethylene	
	COEX	
	PET	
	Polypropylene	
	<b>Total rigid plastic</b>	
Flexible bags	Polyethylene	
	Metallized	
	Paper with interior lining	
	<b>Total flexible bags</b>	
Boxes	Cardboard	

**Figure 10: Template for recording annual quantities of packaging materials**

The distribution of pesticides in the agriculture sector is a function of geography, in terms of land-use throughout the country, and it is related to the seasons during which they are used. In the health sector, geography is a function of the spatial and temporal distribution of vector-borne diseases. In assessing the needs of a container management scheme, it is important to take into account the periods during which the empty containers need to be collected from the users. The assessment should provide an indication of the cyclicity and peaks in demand, the distribution of the sizes and types of container, the quantities for each material, and their geographic distribution.

The output of this assessment will be a specification for the demands that the container management scheme has to meet. The recommended process steps to establish a full-scale scheme are:

- undertake a feasibility study, and if it proves viable, proceed to the next step;
- undertake pilot projects in the different areas of the country with different user groups. If this is successful, proceed to the next step;
- develop a full-scale scheme.

## **2.1 Other agricultural packaging**

This guideline is focused on one-way pesticide containers that are required to be collected from users or delivered by users to collection points. The users are also likely to have packing materials from other agricultural products such as fertilizer sacks and veterinary products that require disposal or recovery. Some agricultural techniques use plastic sheeting as a mulch to protect soil and plants. At the end of the growing season, this requires disposal. These materials require similar recycling and disposal technologies to pesticide containers.

Economies of scale and logistical efficiencies may make it worthwhile providing a combined management scheme for this other packaging and plastic waste along with the empty containers. The combined scheme is likely to have lower costs per tonne collected.

## **3 Mechanisms for developing a container management scheme**

In determining the structure of a container management scheme consideration needs to be given to its legal basis; how it is funded and incentivized; and the practicalities of its infrastructure and logistics.

### **3.1 Legal basis**

There are two models for container management schemes that have been employed to date, the voluntary model and the legally mandatory model.

#### **3.1.1 Voluntary scheme**

The voluntary model is a scheme that foresees an organization to set up a scheme without the support of a legal framework from the government. Organizations that have set up voluntary schemes include the trade associations of pesticide manufacturers, and NGOs. Pesticide trade associations have established many voluntary schemes around the world, as a component of a product stewardship

programme. NGOs have initiated pilot collections schemes that have then developed into fully-fledged schemes.

Voluntary schemes can be successful, particularly where all the suppliers within a country participate in the trade association and contribute to the scheme. However in some markets pesticides are also supplied by manufacturers that do not participate in the trade associations and do not wish to contribute to the container management scheme. The collection of their containers is in effect funded by their competitors. In the long run this is unsustainable. Companies that contribute to the scheme are disadvantaged and eventually will be forced to pull out of the scheme.

Sustainable collection schemes will only be achievable in the long term where there is a secure source of funds. This can be achieved with a scheme that is legally mandated.

### 3.1.2 Legally Mandatory scheme

Legally mandatory schemes are those that are required to be put in place under a country's pesticide regulations. Generally, as part of a pesticides registration and authorization for use, there is a requirement for users to participate in the scheme.

If the country chooses the legally mandatory scheme, a sustainable funding mechanism can be established in the regulations. Where levies are imposed on suppliers of pesticides, all are obliged to fund the scheme. This avoids the problem of "free-riders" that are common in voluntary schemes, as discussed above.

The threat by governments to establish a legally mandatory scheme could be sufficient incentive for suppliers to establish a voluntary scheme.

Legally mandatory schemes can specify the level of service that the scheme provides to the users. A scheme to which it is easy to return empty containers will tend to have a higher collection efficiency. This is certainly the case with the scheme operated in Brazil as outlined in 7.3.

### 3.1.3 Other legal considerations

Whatever the legal basis for the scheme, its operation needs to comply with all relevant national environmental, waste and transportation laws. In addition, there are international frameworks that should be taken into consideration in the design of the scheme, including:

- International Code of Conduct on the Distribution and Use of Pesticides; [1]
- ILO Convention concerning Safety and Health in Agriculture; [11]
- Stockholm Convention in relation to persistent organic pollutants; [12]
- Rotterdam Convention in relation to prior informed consent; [13]
- Basel Convention in relation to environmentally sound management of waste and the transboundary movement of waste; [7]
- Bamako Convention in relation to the transboundary movement of waste in Africa [14].



## 3.2 Economics and incentives

### 3.2.1 Funding

Schemes need to be economically viable if they are to be sustainable. For legally mandated schemes governments should determine how they wish the scheme to be funded. The options include:

- levies on suppliers;
- pesticide sales tax;
- general taxation.

#### *Levies on suppliers*

Levies paid by suppliers are the most common funding mechanism within existing schemes. As discussed above, the management of containers at the end of their life is an external cost directly related to the supply and use of the product. By levying the supplier, these external costs are borne by the organizations responsible for their creation. The quantity of the levy is generally directly proportional to the quantity of pesticides the supplier releases onto the market. Suppliers can raise prices to pass on a proportion or all of the levy to the users. For competitive reasons, suppliers may decide to absorb some of the levy rather than raising prices fully.

#### *Pesticide sales tax*

Pesticide sales tax is paid directly by the purchaser of pesticides, i.e. the user. The amount that the user pays is directly proportional to the amount of pesticide that they buy. It is similar to the levy on suppliers in that the external costs are borne by the organizations and individuals responsible for the empty containers. Unlike the levy, the full cost is passed directly to the user.

#### *General taxation*

A country may decide that the costs of the scheme should be paid by the whole population. In this case the funds would come from general taxation, e.g. where the agriculture sector of a country is weak and unable to bear additional costs of a collection scheme, funding from general taxation is a viable solution.

Section 7 includes examples of container management schemes in Australia, Belgium, Brazil, Canada, Chile, France, Guatemala, Germany, Hungary and the United States of America.

### 3.2.2 Incentives

Financial incentives can be used to encourage users to return empty containers. Incentive schemes have been used for other packaging such as drink bottles and gas cylinders, where a deposit is charged with the initial purchase. The deposit is redeemable on the return of the empty container. A similar deposit scheme for pesticide containers could be used to encourage users to return empty containers.

However, there are no such incentives currently being operated. There are two reasons for this. First, there is concern that the scheme would encourage the illegal collection of pesticide containers by both adults and children that do not have the knowledge, skills and equipment to handle them safely. Second, the accounting and administrative costs of running the incentive scheme can be high.

There are other ways to encourage users to return empty containers. These include:

- awareness raising programmes and education of users about the hazards of empty pesticide containers and how the scheme allows them to return containers free of charge;

- retailers only issuing a new product to a user on return of the empty container from their previous purchase. Operating such a scheme has its complications and would only be suitable in cases where users are regularly applying the same pesticide product. It might have the undesirable effect of encouraging users to hold onto empty containers between seasons.

As well as considering incentives to encourage users to return containers, it is more important to avoid creating disincentives for them not to return them. The scheme should avoid direct charges to users for returning containers. The locations to which the users may return empty containers should be convenient and avoid additional travel.

### **3.3 Infrastructure and logistics**

#### **3.3.1 Administration of the scheme**

Whether the container management scheme is voluntary or mandatory, it is normal practice to constitute a legal entity to administer it. In many of the existing schemes operating around the world, the administrative body is a non-profit company established and funded by the pesticide suppliers.

In exceptional circumstances where the government itself undertakes the supply and distribution of pesticides, the government should also establish and finance the administrative body.

It is the responsibility of the administrative body to develop:

- the logistical infrastructure to collect the empty containers;
- the processes to treat the containers to facilitate easier handling (e.g. shredding or baling) and to separate the materials into fractions according to the intended recycling or disposal route; and
- the appropriate technologies for the sound environmental management of the materials, or establish contracts with external organizations to undertake the recycling and disposal.

#### **3.3.2 Logistics**

Logistics represent a significant cost to a scheme, particularly in countries where the distances between agricultural areas and the recycling and disposal operations are long. Transporting empty containers is also not efficient due to their high volume to weight ratio.

For the scheme to be effective in attracting back empty containers, it must be easy for the users to return them to the scheme. Designing the appropriate infrastructure for logistics is crucial. There are a number of options to consider, as described here below.

##### *Acceptance from users*

Users should be encouraged to return empty containers in a safe manner that does not risk their health or the environment. The safe transportation of pesticides and empty containers should be promoted through awareness raising programmes. The programme should include advice about:

- not carrying pesticides or containers within the vehicle cab;
- safe packing and avoiding breakages;
- safe stowage; and

- transporting limited quantities.

At the time that the user returns the empty containers, there should be a formal procedure for inspecting the containers. Only cleaned and rinsed containers should be accepted into the container management scheme. Containers with residual contamination should be considered as pesticide waste and treated accordingly. The scheme should not reject containers with residual contamination, as this would encourage dumping or misuse of the contaminated container. Instead, the container should be accepted but the user charged for its disposal.

### *Reverse distribution*

Reverse distribution uses the infrastructure that has been established to distribute products to users as a mechanism to receive material back from them. This is efficient because:

- the user has a relationship with a single organization for both the supply of new products and the return of empty containers. When the user returns empty containers at the same time as purchasing new product, their time and transport costs are minimized;
- the vehicles that have delivered product to the retailer, which would normally return empty to the wholesaler, can be used to return empty containers. Likewise, the containers can flow back up the supply chain.

Reverse distribution does have some issues in that the participants in the supply chain will require additional storage to be able to hold both stocks of products and empty containers. Depending on the legislative framework and the classification of the empty containers as waste, the members of the supply chain may require authorization to store and transport waste.

At some point in the reverse distribution chain, the empty containers need to be sent to organizations that operate pre-treatment, segregation, recycling and disposal processes. The point in the reverse distribution supply chain where this should happen will depend on the specific circumstances in the country.

### *Network of collection centres*

As an alternative to the reverse distribution model, a scheme can establish a network of collection centres where users are able to deliver empty containers. The location, opening times and staffing of the collection centres must be convenient to users. Inconvenient locations and opening times will discourage users from returning containers.

The collection centres may be used to undertake segregation of container materials and pre-treatment such as baling and shredding to increase the density and improve the efficiency of the onward transportation. Shredding may also improve the value of the materials for recycling.

For large countries the network could include both local and regional collection centres. The local collection centres provide easy access for users to return containers. The scheme's vehicles can collect from the local collection centres and consolidate the containers at the regional centre. The economies of scale at the regional centre may allow for the pre-treatment and processing to be undertaken efficiently.

Collection centres can be stand-alone facilities dedicated to empty containers, located at sites belonging to members of the supply chain, or located at sites belonging to organizations involved in the recycling and disposal activities.

### *Collection*

The scheme will need to manage the collection of containers from the collection centres. In the case of large-scale users of pesticides, the scheme may elect to collect the containers directly from the user. There are two options for managing the transportation:

- a fleet of vehicles owned and operated by the scheme; or
- contracts with transport companies with licensed vehicles and trained operators to make collections on behalf of the scheme.

### *Pre-treatment*

Pre-treatment involves the processing of containers to improve either the efficiency of transport or the recycling and disposal process. The limiting factors for the load that a vehicle may transport are volume and weight. When carrying empty containers, vehicles reach their volume limit with only a fraction of their maximum payload. By increasing the materials' density with processes such as shredding, baling and crushing, the weight that vehicles carry can be improved significantly.

These pre-treatment processes can be conducted with fixed or mobile equipment. Fixed equipment remains at the collection centre and processes containers that are delivered. Fixed equipment can be scaled to manage the volumes received at the collection centre at continuous process rates. Mobile pre-treatment equipment can be taken around each of the collection centres to process the stockpiles in readiness for their later collection and transport to recycling centres.

As an alternative, mobile pre-treatment equipment can be incorporated into the collection vehicles. This is generally not a favoured option with existing schemes due to the time it takes to shred, bale or crush containers, during which time the vehicle is standing idle.

Specific pre-treatment options are discussed in section 5.

### *Recycling and disposal*

The scheme will have to identify options for the recycling and disposal of container materials. The potential technologies are discussed in section 6. The scheme needs to consider each option and determine whether to invest in and operate the technology directly or to contract with organizations that already operate the technologies.

Where the recycling or disposal options are outside the borders of the country, it is necessary to ensure that the transboundary movement of the materials will be allowed under the Basel [7] and, if applicable, Bamako Conventions [14].

#### 3.3.3 Information and communications

Good communications are crucial to a successful scheme. Users need to be aware of their responsibilities, the techniques for cleaning containers, and where to take containers when they have been emptied and cleaned. The scheme may use any of the following communications channels.

### *Container label*

The registration regulations should stipulate the required information to be displayed on the label. This should be in the local language appropriate to where the product will be marketed. In areas where literacy rates are low, the label should show appropriate symbols demonstrating how the product should be used and how the container should be cleaned. The label should show all the necessary hazard information.

## Education programmes

Education programmes can be run by farmer cooperatives, farmer field schools, NGOs, extension services, agricultural colleges and schools. They can raise awareness of the correct use of pesticides and the disposal of the empty containers. The programmes may be supported by training aids, posters, plays, handbooks in the local language and with illustrations for the illiterate. Education is an integral part of the container management scheme, so should be fully funded by it. Examples of illustrations of good practice are shown in Figure 11 and Figure 12 below.

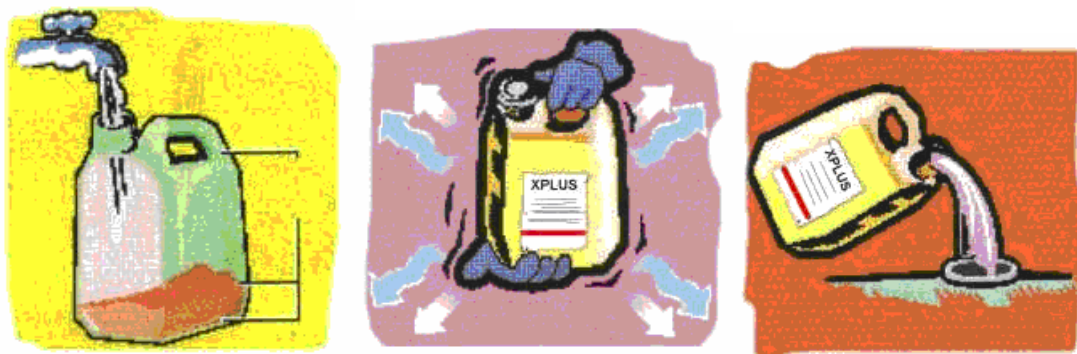

(Copyrighted by Casafe <http://www.casafe.org>)

**Figure 11: Triple rinsing illustrations**

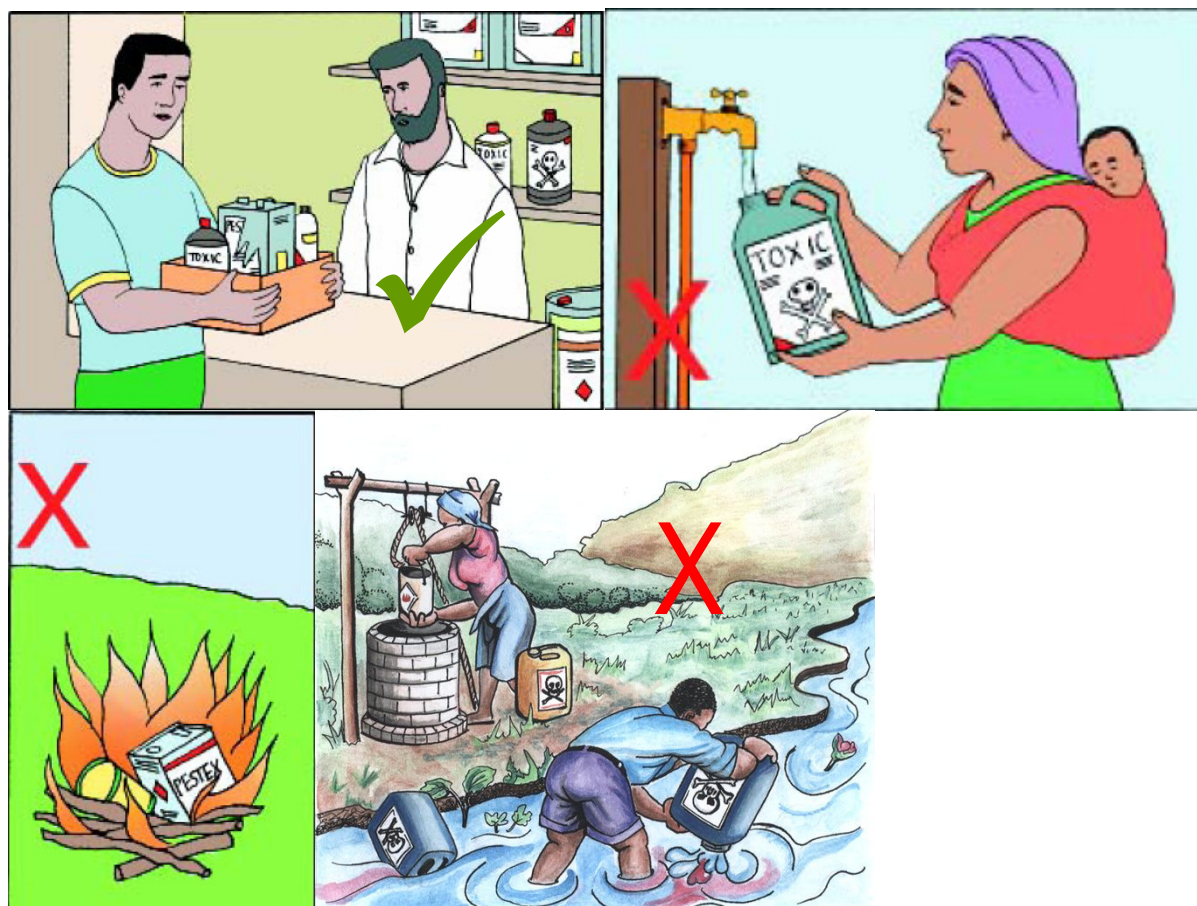

(Copyrighted by FAO, Disposal of Obsolete, Banned and Unwanted Pesticide, Mozambique, project GCP/MOZ/080/JPN - Phase II of the Disposal of Obsolete Pesticide Project)

**Figure 12: Examples of illustrations showing good and bad practice**

For improved acceptance by users, the illustrations should be developed for each education programme to take into account local culture, ethnicity and practices.

### *Publicity campaigns*

In addition to the education programmes, publicity programmes using mass media such as television, radio, cinema and the press can also be used. The cost of such programmes can be high, but with a large and dispersed user community, such campaigns can raise awareness rapidly. The container collection scheme in Brazil run by the National Institute for Processing Empty Containers (inpEV) ran the very successful television and press campaign “lava-me” to communicate the need for triple rinsing.

## **3.4 Countries with low pesticide use**

Countries where pesticide use is relatively low may question whether a container management scheme is needed.

Even with low volumes of pesticide use, the risks to the environment and to human health from inappropriate management of empty containers still exist, especially in the communities that use the pesticides. To avoid these risks, it is necessary that the users have a mechanism for removing the empty containers from their community. It is the responsibility of the country to protect these communities by establishing a container management scheme. The economies of scale and the options available for recycling may be fewer, but the scheme as a minimum should ensure that containers are collected, removed from the communities and disposed of in an environmentally sound manner.

## **4 Farmers and other uses of pesticides**

It is the duty of all users of pesticides to act responsibly when acquiring, storing and applying pesticides. They have a duty to prevent waste, avoid contamination and deal responsibly with the waste pesticides, pesticide residues and empty pesticide containers.

To assist users, they have to be provided with the knowledge and systems to carry out their duties. It is the responsibility of the country to ensure that education programmes and a container management scheme are in place. Education and information programmes are discussed in section 3.3.3.

Pesticides should only be acquired in quantities that are likely to be needed, to avoid the potential for creating obsolete stocks. The pesticides must be stored safely and securely, away from food and water supplies. The storage conditions must comply with the instructions on the label, particularly with regard to ventilation, temperature and light. Pesticide formulations stored in inappropriate conditions may deteriorate such that their shelf-life is shortened. Generally pesticide containers should be stored in the following conditions:

- dry;
- well ventilated;
- maintained at a constant temperature;
- protected from extremes of temperature;

- protected from strong light.

Unwanted pesticides and pesticide residues should never be disposed of on the farm. These wastes should be consigned directly to a waste disposal contractor authorized to destroy them or returned to the supplier.

It is the responsibility of farmers and other users to clean the empty containers immediately following use as detailed in section 1.4. Following cleaning, the containers should be punctured or otherwise rendered unusable and stored safely on the farm prior to being returned to their supplier or one of the container management schemes' local collection centres.

## 5 Pre-processing

Pre-processing can improve the efficiency of the logistics or the recycling and disposal of the empty containers.

### 5.1 Volume reduction

As discussed in section 3.3.2 on logistics, reducing the volume that containers occupy will allow vehicles to carry greater payloads. The common techniques for volume reduction include baling, crushing and shredding. Volume reduction should take place early in the logistics chain from user to recycler or disposer to improve the efficiency of the whole scheme.

#### *Baling*

Baling is a process that compresses loose containers into blocks, which are then held in place with bands. Containers that are suitable for baling are large plastic containers and plastic sacks. Baling small plastic containers requires multiple bands and cardboard or other material to hold the bale together.

Baling only improves the density of the containers which can improve transport efficiency and can increase storage capacity for a warehouse when space is a constraint. Baling does not assist in the recycling or disposal processes.



(Copyrighted by CropLife International)

**Figure 13: Bale of containers**



#### *Crushing*

Crushing is a process that also involves compaction but relates to materials that remain deformed when the pressure of the crusher is released. Typical materials that may be crushed are aluminium and steel drums.

(Copyrighted by FAO)

**Figure 14: Stack of crushed 200 litres drums**

## Shredding

Shredding tears or cuts the containers into small pieces. It is a technique that is appropriate for thin materials that are readily cut, such as plastic, cardboard and aluminium. It is possible to shred steel, but the equipment is extremely large and expensive, and has a high energy demand. For steel drums, crushing tends to be more economical.

Shredding is also a requirement if the container material is destined to be used as an alternative fuel in a cement kiln or power station. Solid alternative fuels such as plastic are required to be blown into these processes, so it is necessary to reduce their particle size.

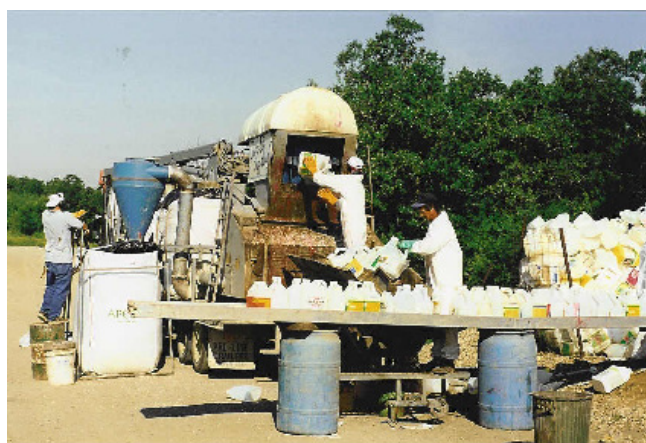

(Copyrighted by CropLife International)

**Figure 15: Mobile shredder**

Shredding is also necessary as a preliminary step before plastics can be converted into new products. In the case of high grade products, the plastic would have to be segregated first to ensure that the shredded material was clean and of a single type.

## 5.2 Material segregation

Where it is the intention to reuse the container as a raw material for another manufacturing process, it is important that the container meets the appropriate specification. In the case of the manufacture of high grade products such as high-density polyethylene (HDPE) rope, lubricant containers, container caps or refuse sacks, the raw material must be a single type of plastic. If there is contamination from another type of plastic, the manufacturing process and the product could be impaired. The segregation process can involve the removal of labels from containers, removing caps and separating the containers into their respective types of plastic. This is a costly process but leads to a segregated material of higher value than that of unsegregated materials. The need and justification for segregation will be determined by the comparative market values for high grade products, low grade products and alternative fuels.

# 6 Recycling and Disposal

The recycling and disposal options are listed in the order in which they occur in the waste management hierarchy (section 1.4). The hierarchy should only be used as one of the many contributing factors that influence the choice of the waste management option. It is important to take a wide view and consider all the environmental and external costs of the processes that lead up to the recycling / disposal as well as their own impacts.

## 6.1 Recycling into new products

Many of the most advanced container management schemes recycle the collected materials into new products. Provided that the container materials can be properly segregated into sufficiently pure



components they can be readily recycled. The components include all the materials identified in Figure 10:

- glass;
- steel;
- aluminium;
- cardboard; and
- various different types and grades of plastic.

High quality and high value plastic products require pure and specific raw materials, so it is very important that the different types of plastic are kept separate. It is possible to make some low grade and low value products from mixed plastics.

The scheme needs to take care over the eventual products that will be manufactured from the reclaimed materials. The materials may still have very low concentrations of pesticide contaminants which could potentially cause harm in some uses. The glass, steel and aluminium will be made into new products after having been melted at high temperature. The process of melting and re-refining of these materials is sufficient to destroy any remaining pesticide residues. These materials can be sold directly into the secondary materials market.

The situation with plastics is different. The melting temperatures of plastic materials are relatively low and may be insufficient to destroy or drive out the pesticide contamination. In this case the scheme needs to ensure that the recycled plastic is manufactured into products with limited potential for human contact and are not likely to be recycled again, for example the electrical conduit. To ensure this is the case, the scheme may wish to manufacture appropriate products itself. The scheme in Canada has manufactured agricultural fence posts and railway sleepers from container plastics. Both these products have very limited human contact. However the market for these products is not strong. In Brazil, the container management scheme manufactures a wide range of high grade products including HDPE rope, electrical conduits, plastic paving slabs and refuse sacks. It also manufactures plastic wood from mixed plastics.



(Copyrighted by CropLife International)  
**Figure 16: Shredded plastic**

Mobile units that manufacture plastic wood from unsegregated plastic containers are used in Argentina. They have the potential advantage of volume reduction and product manufacture close to the first collection points.



(Copyrighted by CropLife International)

**Figure 17: Fence posts**



(Copyrighted by CropLife International)

**Figure 18: Sewage pipes**

## 6.2 Resource Recovery

All the different types of plastic materials used for pesticide containers have a high caloric value which can be used as alternative fuel in the clinker production process in cement kilns (co-processing). With the increasing scarcity and high cost of fossil fuels, thermally intensive industries, such as cement manufacture, are seeking alternative fuels. The clinker production process is also effective in the destruction of pesticide residues in the containers because it requires a long residence time at high temperatures in an alkaline environment.

For safety reasons, all emptied pesticide containers must be cleaned and shredded prior to their delivery to the cement plants and before their introduction into the cement kiln. The material introduction system of the cement kiln may need to be adapted to enable the processing of the shredded containers. National environmental regulations may require special operating permits, and such operation may be subject to regular monitoring.



(Copyrighted by W. Schimpf, GTZ)

**Figure 19: Cement kiln in the Philippines**

The plastic waste can also be used as alternative fuel in a steel blast furnace to reduce iron ore. This process can also accept mixed plastics as the temperature of the furnace is sufficiently high to destroy residual pesticide contaminations.

Despite resource recovery being lower down the waste hierarchy than recycling, for many schemes (including the Canadian scheme, see also chapter 7). It is the preferred solution from an economic perspective. With high oil prices, alternative fuel prices have also risen, providing higher revenues to the scheme. When coupled with the savings for not having to segregate the plastics into their different components, resource recovery can represent an attractive outlet for the recovered plastics.

## 6.3 Disposal

Where recycling is not possible, containers will have to be disposed of. There are two generic disposal processes, destruction and sequestration, as discussed in the waste hierarchy in 1.4 above.

### *Destruction*

Where the containers still represent a hazard due to levels of contamination, destruction is preferred over sequestration, as the hazards associated with any residual pesticide contamination are removed by the destruction process. There are several destruction technologies that have been proven for pesticide wastes. These include:

- high temperature incineration;
- base catalyzed dechlorination;
- gas phase chemical reduction;
- plasma arc.

These processes are described in detail in FAO's forthcoming disposal guidelines and by the Global Environment Facility's (GEF) Scientific and Technical Advisory Panel (STAP) in their report on emerging disposal technologies.

High temperature incineration is currently the most widely established and economical disposal option. Incineration plants are widely distributed throughout Europe and North America, but there are few in other regions and none in Africa.

### *Sequestration*

In the case of rinsed containers that are classified as non-hazardous, sequestration is an appropriate disposal technique. The most common form of sequestration is a specially engineered containment landfill site. A landfill site of this type is generally designed on geologically stable substrata, with a clay layer and impermeable HDPE membranes to prevent any contamination from the landfill escaping and contaminating soil and groundwater. The landfill site should be licensed by the country's regulatory authorities and managed in accordance with its site licence. Clean packaging of all types (wood, paper, cardboard, plastic, glass and steel) is appropriate for disposal in a licensed landfill when there are no recycling or resource recovery options available.

## 7 Examples of schemes

This section includes ten examples of container management schemes operating throughout the world in industrialized and developing countries. Some of the examples were presented at the OECD Seminar on "Pesticide Risk Reduction through Good Container Management" [1]; other examples were received from CropLife International. The description below of the ten examples is intended to provide an overview of the schemes established in different countries.

## **7.1 Australia**

### *Who and How*

Australia's national container management scheme, "drumMUSTER", is a full stewardship programme developed by industry, the National Association for Crop Production and Animal Health (Avcare Ltd), the Veterinary Manufacturers and Distributors Association (VMDA), the National Farmers' Federation (NFF) and the Australian Local Government Association (ALGA). Launched in 1999, drumMUSTER is administered by an independent non-profit organization, Agsafe Ltd, a wholly-owned subsidiary of Avcare Ltd. Agsafe has entered into 456 agreements with local governments which undertake the collections in their jurisdictions. Agsafe Ltd also runs a collection programme for currently registered obsolete pesticides.

### *Policy Context*

The drumMUSTER programme is an industry voluntary scheme. It is part of the country's waste management policy based on extended producer responsibilities and waste reduction at source to minimize the amount of packaging materials going to landfills. Under an Industry Waste Reduction Scheme (IWRs) Memorandum of Understanding (MoU) signed with programme stakeholders, agricultural and veterinary chemical manufacturers charge a levy of Australian \$ 0.04 (€ 0.024) per litre or per kilogram on most products sold in non-returnable containers to fund the drumMUSTER programme. Thus, the programme is ultimately paid for by farmers, in line with the polluter-pays principle. However, the agreement to charge the levy required a special authorization from the Australian Competition and Consumer Commission, as it could have been considered an uncompetitive practice.

### *Results*

In 2003, drumMUSTER collected about 35 percent of total containers sold (primarily 20 litres containers), which deliver nearly 70 percent of the total volume of agrochemical and veterinary chemicals sold in Australia. Between 1999 and April 2004, over 5 600 collections of cleaned one-way containers (two-thirds were recyclable plastic, the rest was steel drums) resulted in 4.85 million drums being removed from farms, representing over 7 400 tonnes of waste diverted from landfills. Most of the recovered material is remanufactured in to recycled products, with a small share reconditioned for reuse as agrochemical and veterinary chemical containers. The reported operating cost of the programme is € 759/tonnes.

## **7.2 Belgium**

### *Who and how*

Phytofar-Recover administers Belgium's national container management scheme. It was established in 1997 by Phytofar, the Belgian Association of Crop Protection Industry. Members are invoiced annually to finance the container management scheme, in proportion to the actual volume of packaging material they put on the market.

Phytofar-Recover handles primary packaging - packaging materials that are in direct contact with the product - exclusively for professional agricultural use. The annual collection period for industrial primary cans and packages from farmers and horticulturists is from September to November, after the end of the spraying period. Rinsed containers are collected in transparent bags provided by Phytofar-Recover, separately for cans and for paper and cardboard containers. The operation is divided into three types of pesticide users; i) farmers and horticulturists, ii) spraying companies, and iii) users of

large barrels over 60 litres. Registered waste collectors are contracted for the collection of two types of used containers, hazardous and non-hazardous. The waste collectors are required to certify that the collected material is incinerated at authorized facilities with energy recovery or recycled. Phytofar-Recover also runs a biannual collection and treatment of obsolete pesticides. It also runs a smaller scheme in Luxembourg.

### *Policy Context*

In 1993, an eco-tax on containers of agricultural pesticides was introduced at € 0.124 (BEF 5) per packaged litre. However, an exemption was granted if a system of collection and treatment of empty containers was to be established, and the total collection reached the minimum of 80 percent of empty packing of pesticide products marketed during the year. This prompted Phytofar to establish a national container management scheme. However, this eco-tax was later abolished in 2003. The 1997 Agreement on Regional Cooperation Concerning the Prevention and the Management of Packaging Waste requires the final user to hand in and those in charge of packaging to collect and recover packaging waste, in order to promote recycling and valorization of the waste.

### *Results*

In 2003, 483.36 tonnes of pesticide packages were collected, representing over 92 percent of the estimated total weight of containers put on the market that year. About 72.5 percent of the collected containers were non-hazardous, and the rest hazardous. The programme cost in 2003 (not including obsolete pesticides) was € 704 229. The cost per kilogramme has declined over the years.

## **7.3 Brazil**

### *Who and how*

In Brazil, the collection and recycling of used pesticide containers started as an industry initiative, which was later reinforced by the introduction of a new law requiring farmers, pesticide distributors and producers to return, collect and provide proper final destinations (recycling and incineration) for used containers. In 1993, Brazil's national pesticide industry association (ANDEF) entered into a voluntary agreement with the Agriculture Secretary of the state of Sao Paulo and the sugarcane planters' cooperative to launch a pilot container management scheme. Collected containers were taken to a small plastic recycling company. In the subsequent years, additional states joined hands with ANDEF to promote triple rinsing and to establish collection centres in strategic locations. By the end of 2001, there were 30 such centres in Brazil. Meanwhile, the recycling industry also grew. In December 2001, the National Institute of Empty Containers (inpEV), a non-profit entity dedicated to managing the final destination process of empty pesticide packages, was established, bringing together Brazil's pesticide industry, distributors and farmers.

### *Policy Context*

In 2002, a law regulating the final destination of empty agrochemical containers entered into force. By then there was sufficient experience from the voluntary programme of collection and disposal of containers begun earlier. The law requires farmers to practise triple rinsing, return empty containers to receiving stations, and keep the vouchers of package delivery and invoice of product purchase. Distributors are required to indicate on invoices where the growers are to return the used containers, construct and manage receiving stations, and implement educational programmes for end users. Pesticide manufacturers are required to: provide transport, recycling or disposal services for empty packages collected at receiving stations; modify labels to include information about triple rinsing and

returning used containers; and implement educational programmes for end users with distributors and government.

### *Results*

As of mid-2004, inpEV, in a joint programme with distributors, administered 260 collection centres. By the end of 2004, there were about 300 centres, with the goal of eventually increasing the number to 350 – 400. In 1994 there was just one small plastic recycling facility. By the end of 2004, there were nine recycling plants in Brazil. The collection rate varied from state to state: 85 percent in the State of Bahia and 84.2 percent in Paraná, to 21 percent in Espírito Santo and less in some other states in May 2004. In 2003, the total collection was in the order of 7 800 tonnes, representing 35 percent of total packages sold. In 2004, 15 300 tonnes were collected, representing an improved collection rate of 65 percent.

About 95 percent of what is sold can be recycled (plastic, metal, etc.) and the rest is incinerated. InpEV runs extensive awareness and education campaigns, including television advertisements and posters promoting triple rinsing and taking back used containers to collection centres, with positive changes in farmers' behaviour.

## **7.4 Canada**

### *Who and How*

In Canada, the most common type of agricultural pesticide container is plastic 10-litre jugs. "Stewardshipfirst", a voluntary pesticide container management scheme, is led by CropLife Canada, a national pesticide industry association representing manufacturers and distributors. It administers collection and recycling with matching funds from federal and provincial governments. In addition, there is a levy charged to all pesticide manufacturers at CAD 0.54 (about USD 0.36) per container put on the market to fund the collection and recycling scheme.

Users take clean empty plastic containers to over 1 250 collection sites across Canada. Five contractors carry out the collection and shredding of used containers, which are then sent to three contractors for recycling. The granulated plastic is recycled into fence posts for agricultural use highway guardrail posts or used for energy. CropLife Canada also runs a parallel programme to address obsolete pesticides.

### *Policy context*

Federal pesticide regulations require pesticide labels, for both agricultural and domestic use to include directions on container management and disposal. For agricultural pesticides, the labels indicate that the container is recyclable and should be returned to a collection centre. For residential pesticides, labels instruct that the container be disposed of along with household waste. Federal and provincial waste regulations stipulate that containers of some pesticides be treated as hazardous wastes.

### *Results*

Canada's container management scheme collects and disposes of 658 tonnes annually. In 2003, 5.4 million containers were collected, adding up to over 55 million containers since 1989. Today, producers across Canada collect on a voluntary basis approximately 70 percent of all containers put on the market. The total annual programme cost is CAD 4 million (USD 2.9 million).

## 7.5 Chile

### *Who and How*

The programme started in 2001 with four Collection Centres (figure 20). It then grew steadily from 13 centres in 2004 up to 25 at the beginning of 2008, now covering a high percentage of the country's collection needs, see also table 4.

Pesticide dealers and distributors are part of the scheme and support it through minicentres which serve for the collection and storage of the containers.

In 1993 the “National Association of Manufacturers and Importers of Crop Protection Products” (AFIPA) introduced triple rinsing and established this programme in cooperation with national authorities. Since then, AFIPA has been training the personnel at the Collection Centres to ensure that all containers collected comply with the triple rinsing requirements.

The collected plastic containers are shredded and stored in jumbo polyethylene bags at each Collection Centre, and are later shipped to cement factories, recycling plants or landfill facilities according to the authorizations given by the Ministry of Health (Ministerio de Salud).



(Copyrighted by CropLife America)

**Figure 20: Collection Centre in Chile**

### *Policy Context*

In 1997 the triple rinsing technique became part of official labelling requirements. This was the basis for a pilot programme in 1998/1999 and the involvement of the distributors/dealers.

In June 2003, the Ministry of Health published the “Sanitary Regulation for the Management of Hazardous Waste”, which stated in article 24 that triple rinsed containers are classified as non-hazardous waste and must be handled according to a disposal programme approved by the Authority which promotes AFIPA's container management programme

### *Results*

Following the establishment of the infrastructure, the amount of containers retrieved has increased consistently over the years.

Year	Volume of plastic retrieved (Kg)	Volume of metal retrieved (Kg)
2001	12,946	1,321
2002	33,034	3,776
2003	81,192	12,584
2004	86,212	13,237
2005	132,316	9,800
2006	147,655	10,512

**Table 4: Examples of country's collection results**

An essential element of the programme was training the farmers (applicators) and the network of distributors/dealers, of whom up to now nearly 20 000 have been trained.

Appropriate and efficient management of crop-protection products	18 946
Applicators certified	502
Total	19 448

**Table 5: Training of applicators and technicians between 2001-2006**

The course offered by the Ministry of Agriculture, granting a Certificate for Application, requires know-how on the triple rinsing technique and the management of empty containers. Follow-up and monitoring of the operating conditions at the collection centres is conducted by AFIPA and national authorities.

According to the sanitary resolutions, the current priority for the final destination of plastic containers is to use them as an alternative source of fuel at cement factories; all the metal containers are recycled at steel companies' furnaces; and a small percentage are delivered to authorized landfills.

## 7.6 France

### *Who and How*

Adivalor, a voluntary organization that administers container management in France, was established by the French pesticide industry association, l'Union des Industries de la Protection des Plantes (UIPP). Adivalor brings together agricultural organizations, pesticide manufacturers and retailers to collect and dispose of used pesticide containers in an environmentally responsible manner.

Responsibilities and costs are shared. Farmers are urged to properly rinse and store their containers and to bring them to the 3 650 collection stations across France. Distributors have to inform their customers how to dispose of their empty containers, and organize and control collection (bearing about one-third of the cost). Producers of crop protection products are responsible for the transport and recovery of the containers (bearing about two-thirds of the cost) in addition to providing scientific data regarding their products. Collected containers are incinerated, at an average cost of about € 480/tonne, at cement kilns and incineration plants of hazardous waste management companies with energy recovery. Adivalor also administers a parallel programme addressing obsolete pesticides, for which public authorities contribute by providing subsidies (but not for the container management programme).

### *Policy Context*

Regulations concerning crop protection product waste prohibit burying or burning, mixing of professional waste in household waste streams and, if hazardous, require disposal at authorized facilities. In France, rinsable pesticide containers (about 70 percent of packages marketed in France) are classified as hazardous waste by law, but Adivalor is negotiating with the French authorities for possible revision of the classification. If properly rinsed containers are to be classified as non-hazardous, this would help lower the cost of incineration significantly (to about € 100/tonne or less).



## Results

A national average collection rate of 25 percent was achieved in 2003, with varying rates (5-50 percent) among localities. Adivalor plans to raise the national collection rate to 50 percent in the coming years. The scheme collected 1 840 tonnes of rigid plastic containers in 2003. Compared with the 2002 total of 1 300 tonnes, this represents a 41 percent increase. However, the growth was lower than expected. One possible reason is the 10 percent decrease in the consumption of pesticides in 2003. In 2002, larger plastic containers holding 25 to 300 litres were collected by Adivalor for the first time. Previously, the scheme had only collected small plastic canisters with a maximum capacity of 25 litres. In 2003, the cost of the container management programme was € 2 kg of packaging material.

## 7.7 Guatemala

### *Who and How*

Through the incineration of approximately 5 tonnes of chipped/shredded plastic containers incinerated in a cement kiln, the programme “Collection and Disposal of Agrochemical Containers” (“Recolección y Eliminación de Envases de Agroquímicos”) was launched in March 1999.



**Figure 21: Example of Campo Limpio**  
(Copyrighted by CropLife America)

It was CropLife Latin America that initiated the programme, though later on member companies from the national Agrochemical Trade Association (AGREQUIMA) joined the initiative. The major challenge of this programme had been the training of the farmers to routinely triple-rinse the containers and to return the rinsed containers to the collection sites. The crucial issue of the programme was cooperation with the agricultural, health and environmental authorities as well as with the distributors and their network that allowed the improvement of the training and facilitated the collection of the containers. The programme is now well known in Guatemala as “Campo Limpio” (“Clean Countryside”).

Major collection centres with the necessary equipment and almost 350 centres have been installed in the country to date.

### *Policy Context*

In order to overcome the initial funding hurdle, a special fund was established with support from the authorities to sustain the container collection programme as well as training farmers regarding the use of pesticides. The fund is based on a special import tax for agricultural products. The willingness of the authorities to cooperate in this programme was another key element for its success.

The authorities in Guatemala have acknowledged the classification of triple-rinsed containers and non-hazardous waste.

## Results

While the programme started with the collection of 70 tonnes in year 2000, it has now in 2008 collected already more than 60 percent of all containers (i.e. 230 tonnes allocated of the 350 tonnes annually sold).

The high price of plastic and the possibilities for recycling have led to an initiative from AGREQUIMA to import empty containers from neighbouring countries, e.g. El Salvador, Honduras and Nicaragua, where the “Campo Limpio” programme has been also introduced.

## **7.8 Germany**

### *Who and How*

PAMIRA, a voluntary used pesticide container collection scheme in Germany, was established in 1996 by the Crop Protection, Pest Control and Fertilizer Association (IVA) following a few years of pilot projects led by the German crop protection industry. In January 2003, the management of PAMIRA was transferred from the Chemistry Business Promotion Corporation (CWFG) to the Corporation for the Recovery of Industrial and Commercial Plastic Packaging (RIGK), one of the four recovery companies already involved in PAMIRA. IVA still maintains political oversight of PAMIRA. The industry finances the costs of PAMIRA according to the proportion of primary packaging material put on the German market. The distributors and retailers provide the collection centres.

PAMIRA collects empty rinsed primary packages up to 60 litres in capacity. Farmers return rinsed primary packages, free of charge, to 230 collection centres throughout Germany during a limited period (one to four days) each year. At the collection centres, inspectors check returned containers to ensure that only properly rinsed ones enter the waste stream. If a container is deemed not sufficiently clean, it is not accepted for free (the farmer either comes back once it is properly cleaned, or pays a fee for depositing the unclean container). They are shredded and transported to reconditioning plants to prepare the material for final disposal/thermal recovery in cement kilns, or for conversion into methanol. The plastic containers collected by PAMIRA are not recycled into new products as in Australia and Brazil.

### *Policy Context*

The collection scheme of PAMIRA is fully in line with the 1998 Germany Packaging Ordinance (Verpackungsverordnung). As for the design of pesticide containers, several EU regulations apply including; Directive 91/414 on placing pesticide products on the market, Dangerous Preparation Directive (for use of chemicals), Transport Legislation, Packaging and Packaging Waste Directive (package design and disposal), and Seveso II (warehousing). Most plant protection products are classified as hazardous for transportation, which requires UN-approved primary packs. Thus, packaging design must take into account all logistical aspects for all modes of transport, warehousing, application and the route of disposal of used (and rinsed) primary packages. On the other hand, properly rinsed and inspected used pesticide containers in Germany are classified non-hazardous and are plastic packaging according to the European Waste Catalogue. Therefore, inspected empty containers are not classified under transport regulations.

### *Results*

In 2003, PAMIRA processed and recycled about 1 547 tonnes of packaging materials. This represents a national average return rate of 52 percent. The return rate varies across the country, ranging from 92 percent in Schleswig-Holstein to 13 percent in Rhineland-Palatinate. The cost of PAMIRA in 2003 was € 1 075/tonne.

## **7.9 Hungary**

### *Who and How*

During the 1970s and 1980s, Hungary had higher levels of pesticide consumption than today, generating 7 000 – 8 000 tonnes of packaging waste annually. There were routine collections and recycling of metal and glass pesticide containers. There was also a private enterprise which carried out the cleaning and recovery of plastic containers, but it was shut down in the mid-1980s due to economic problems. Hungary started again with newly defined goals and revised regulations that clearly define the division of responsibilities. In 2003, CSEBER, a non-profit coordinating organization for a national pesticide container management scheme, was established by 20 pesticide producers. Ninety collection centres have been established. All pesticide manufacturers have to join CSEBER, or to meet the regulatory requirements for container management alone. Members are charged collection fees of € 0.04/litre (for 2-25 litre containers), € 1.00/container (for 26-60 litres containers), € 2.00/container (for 61-250 litre containers) and € 3.50/container (for those over 250 litre). Collected packaging materials are transported by three contractors and incinerated at three facilities with energy recovery.

### *Policy Context*

The Government Decree 94/2002 on Packaging Waste Management makes pesticide manufacturers and importers responsible for the collection, reuse and recovery of used pesticide containers through a designated coordinator, and sets the fees for used container recovery. The Ministerial Decree 103/2003 on Pesticide Packaging Waste requires farmers to practise triple rinsing, and hand over clean used containers to designated collection sites. CSEBER is required to keep record of its collections.

### *Results*

CSEBER's first collection in 2003 resulted in about one million containers (760 tonnes of plastic/glass/metal) collected, representing 45 percent of the pesticide packaging material put on the Hungarian market. The 2000 Waste Management Act had set forth a target recovery rate of 50 percent of all packaging wastes by July 2005. The programme cost in 2003 was € 720 000, most of which was for transport and recovery.

## **7.10 USA**

### *Who and How*

Established in 1992, Ag Container Recycling Council (ACRC), a non-profit organization funded by CropLife America companies and seven other affiliate members, carries out a voluntary pesticide container collection and recycling scheme in the United States.

Final users bring rinsed empty plastic containers to collection sites, where they are inspected and accepted free of charge. Only non-refillable, HDPE plastic pesticide product containers for agricultural use are accepted by the ACRC. Four ACRC contractors grind the collected plastic containers into flakes, which are shipped to approved recyclers which produce non-consumer products such as field drain pipes, marine piling, etc. The ACRC recycling scheme is funded by member dues in proportion to the weight of plastic pesticide containers put on the US market, and determined by the total ACRC budget.

### *Policy context*

Federal pesticide regulations require labels to provide directions on container management and disposal. New regulations on container design and bulk containment are currently under consideration. Recycling and disposal of used pesticide containers are impacted by federal and state regulations that designate some pesticide containers as hazardous waste. State governments regulate open burning and landfilling of wastes, also affecting disposal options.

### *Results*

The US container recycling scheme collects about 7 million pounds (3 175 tonnes) or about 10 million containers annually. This represents roughly 28 percent of plastic pesticide containers used by US farmers each year (35 million). Since 1993, over 65 million pounds (29 484 tonnes) or about 93 million containers have been recycled. The total annual programme cost is USD 3.9 million, of which over 80 percent is spent on container collections.

### **7.11 Performance of container management schemes around the world**

Statistics have been compiled of the collection performance of a number of schemes that are operated around the world. The analysis compares the quantity of containers put onto the market with the quantity of empty containers that are managed by the schemes. The analysis is shown in Figure 22 below. It should be noted that the scheme operated in Brazil has the highest collection efficiency. This scheme was one of the first to be put in place and is supported by a strong regulatory environment and the involvement of all stakeholders. The scheme has developed extensive communication programmes with television and press advertising, together with education programmes for pesticide users. The scheme is described in more detail in section 7.3.

Country	Weight of pesticide packaging shipped into Market (kg)		Weight of Pesticide Packaging collected (kg)		% Collected	
	2004	2005	2004	2005	2004	2005
USA	18 000 000	18 000 000	3 600 000	3 564 000	20.0	19.8
Canada	2 778 300	2 960 264	1 950 480	1 975 616	70.0	67.0
Argentina	5 700 000	5 700 000	102 600	501 600	1.8	8.8
Bolivia	537 000	537 000	19 869	39 738	3.7	7.4
Brazil	11 706 283	15 707 000	10 067 403	13 665 090	86.0	87.0
Chile	100 000	130 000	20 000	26 000	20.0	20.0
Colombia	2 365 000	2 365 000	148 995	182 105	6.3	7.7
Costa Rica	650 000	650 000	144 950	200 200	22.3	30.8
Dom Republic	140 000	140 000	36 960	40 600	26.4	29.0
Ecuador	300 000	300 000	0	24 900	0.0	8.3
El Salvador	355 000	360 000	99 400	136 800	28.0	38.0
Guatemala	350 000	350 000	120 050	177 450	34.3	50.7
Honduras	215 000	250 000	39 990	74 000	18.6	29.6
Mexico	3 220 000	5 450 000	199 640	348 800	6.2	6.4
Nicaragua	350 000	350 000	0	0	0.0	0.0
Panama	315 000	315 000	22 050	31 500	7.0	10.0
Paraguay	1 150 000	2 400 000		792 000		33.0
Peru	625 000	800 000	6 250	32 000	1.0	4.0
Uruguay	166 000	450 000	6 640	22 500	4.0	5.0
Venezuela	900 000	900 000	0	27 000	0.0	3.0
Australia and New Zealand	2 744 666	2 049 021	1 070 420	1 106 471	39.0	54.0
Austria	350 000	350 000	245 000	245 000	70.0	70.0
Belgium	585 000	585 000	538 000	538 000	92.0	92.0
France	7 500 000	7 500 000	3 200 000	3 200 000	42.7	42.7
Germany	3 200 000	3 000 000	1 760 000	1 950 000	55.0	65.0
Hungary	2 763 000	2 763 000	1 263 000	1 263 000	45.7	45.7
Poland	2 000 000	2 000 000	550 000	550 000	27.5	27.5
Spain	6 672 000	6 672 000	1 072 000	1 072 000	16.1	16.1
The Netherlands	1 271 000	1 271 000	571 950	1 143 900	45.0	90.0

### Regions

N-America	20 778 300	20 960 264	5 550 480	5 539 616	26.7	26.4
LATAM	29 144 283	37 154 000	11 034 797	16 322 283	37.9	43.9
Australia/NZ	2 744 666	2 049 021	1 070 420	1 106 471	39.0	54.0
Europe	24 341 000	24 141 000	9 199 950	9 961 900	37.8	41.3
<b>Total</b>	<b>77 008 249</b>	<b>84 304 285</b>	<b>26 855 647</b>	<b>32 930 270</b>	<b>34.9</b>	<b>39.1</b>
Estimate (global):		190 000 000		32 930 270		17.3

**Figure 22: Performance of Container Management Schemes around the world (source CropLife 2006)**